

B

**SMITH® JAY R. SMITH MFG. CO.®**  
 DIVISION OF SMITH INDUSTRIES, INC.  
 POST OFFICE BOX 3237  
 MONTGOMERY, ALABAMA 36109-0237 (USA)  
 TEL: 334-277-8520 FAX: 334-272-7396 www.jrsmith.com



LOCATION

DRAWING NUMBER  
**S2005 (-F37)**

SIZE  
**A**

SCALE:  
**NONE**

DATE:  
**6-3-02**

APPROVED BY:

CHECKED BY:

DRAWN BY:  
**RN**

**2005 (-F37)**

WE CAN ASSUME NO RESPONSIBILITY FOR USE OF SUPERSEDED OR VOID DATA

# FLOOR DRAIN

**FUNCTION:** Used in a non-traffic area when a funnel type strainer head is required and space does not allow use of the 3500 Series funnel. The extended rim allows use as an anti-flood and anti-splash drip pan.

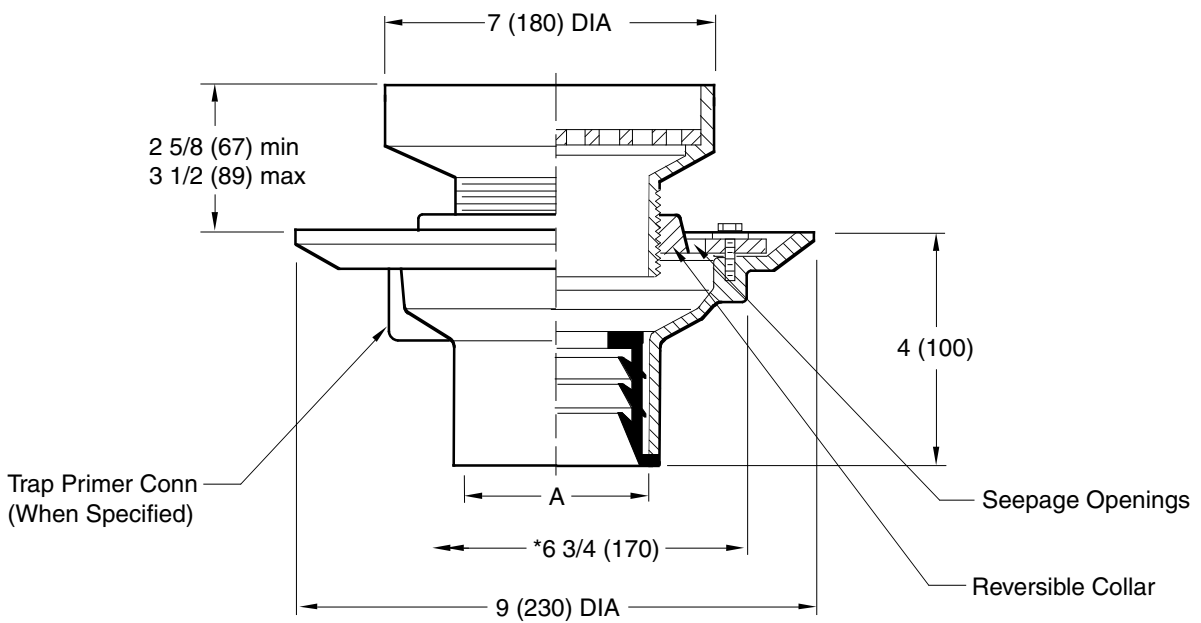

A (Pipe Size) = 02(50), 03(80), 04(100), 05(125) or 06(150)

Fig. 2005Y (-F37) . . . . . NO-HUB OUTLET

**NOTE:** Dimensions shown in parentheses are in millimeters.  
**NOTE:** \* MIN 6 3/4 (170) hole required for core drilled applications.

**REGULARLY FURNISHED:**  
 Duco Cast Iron Body and Flashing Collar, Adjustable Nickel Bronze Strainer Head as Indicated by Suffix Letter Selected. Flush with Floor Funnel with anti-Splash Rim and Grate.

**VARIATIONS:**

- Trap Primer Connection -P050 1/2" (13)& -P075 3/4" (19)
- Vandal Proof Screws -U
- L Speedi-Set Service Weight 02(50), 03(80) & 04(100) sizes only
- LXH Speedi-Set Extra Heavy 02(50), 03(80) & 04(100) sizes only

**OPTIONAL MATERIALS:**

- Bronze Body -BB
- Chrome Plated Top -CP
- Galvanized Cast Iron Body -G
- Polished Bronze Top -PB

FIGURE NUMBER	REV.	DATE	DESCRIPTION	BY	CKD. BY	WEIGHT POUNDS	VOLUME CUBIC FEET	FIGURE NUMBER
B		4-19-07	Added Gasket & Nickel Bronze to REG.	RN	AL			<b>2005 (-F37)</b>
A		04/14/03	Added 6" Pipe Size	JJ	CL			