

# LEAD CAULKING PROCEDURE

1. Gap between hub and spigot end should be equal all around the hub.
2. Yarn or pack oakum tightly with appropriate yarning iron to a point approximately 1" below top of hub.
3. Make first lead pour to a point approximately 1/2(13) - 3/4"(19) below top of hub.
4. Using a caulking iron placed in the middle of the lead ring, drive the lead and oakum down until packed tightly.
5. Make second pour to top of hub. NOTE: All pours should be one continuous pour to eliminate the possibility of cold shuts in the lead which can cause leaks.
6. Using the outside caulking iron, drive lead ring into outside of the hub.
7. Using the inside caulking iron drive leading into the spigot end of the pipe. NOTE: Care must always be taken to not pack the lead too tightly, to insure the hub will not crack.

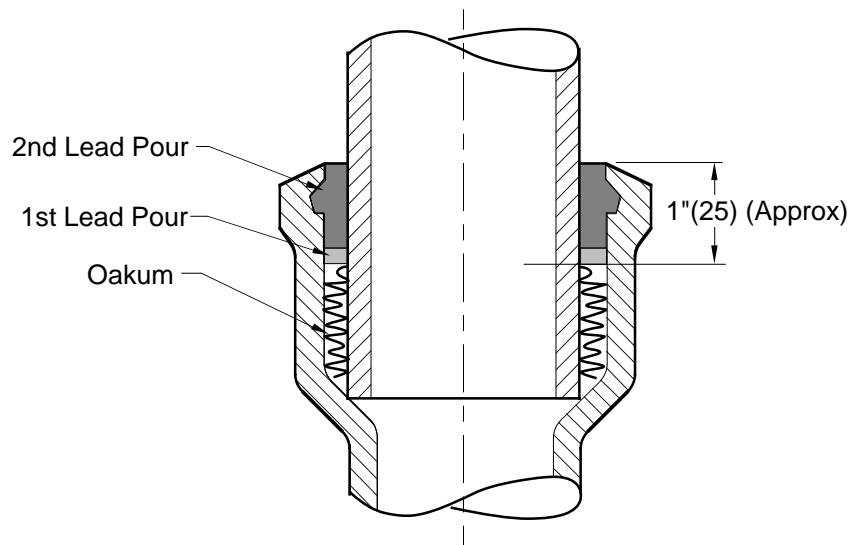

## CAULKING TOOLS

