

TYPE NO. 5 PVC NIPPLE WITH INTEGRAL TEST CAP

For use with 0100, 0200, 0300 and 0400 series supports.

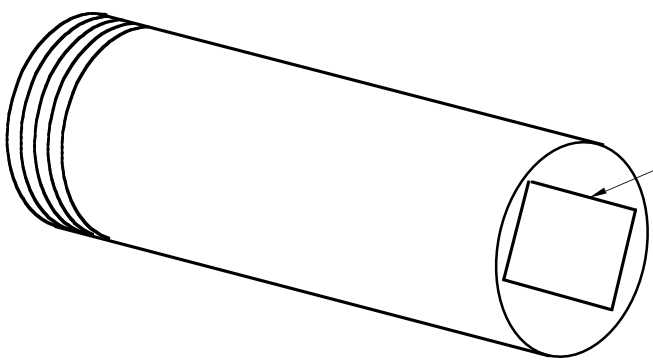

TEST CAP
 AFTER TESTING CUT END SQUARE TO DESIRED LENGTH.

NOTE: NIPPLE SHOULD EXTEND 5/16" (8) BEYOND FINISHED WALL.

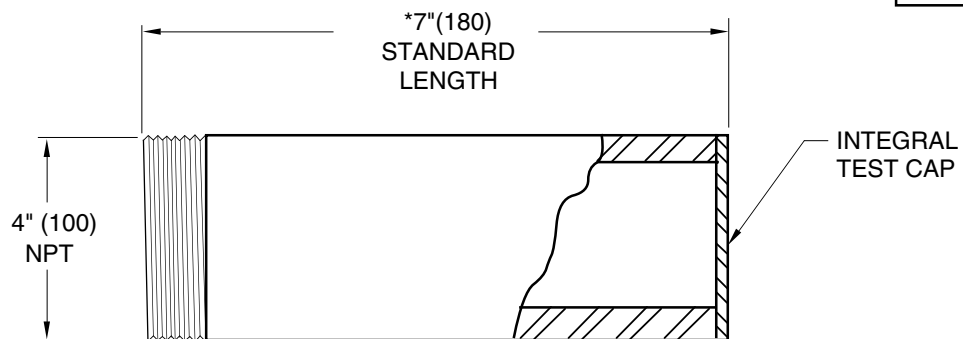

NOTES: See instruction label affixed to face of test cap.
 *7" (180) long nipple is regularly furnished (schedule 40). Longer lengths available when specified.
 Dimensions shown in parenthesis are in millimeters.

TYPE NO. 5
 DRAWING NUMBER: **TYPE NO. 5**
 SIZE: **A**
 SCALE: **NONE**
 DATE: **6-6-78**
 APPROVED BY: **T.S.**
 CHECKED BY: **T.S.**
 DRAWN BY: **T.S.**
 DIMENSIONS ARE SUBJECT TO MANUFACTURERS TOLERANCE AND CHANGE WITHOUT NOTICE
 WE CAN ASSUME NO RESPONSIBILITY FOR USE OF SUPERSEDED OR VOID DATA

FIGURE NUMBER	B	4-18-96	Revised & updated	CMB		WEIGHT POUNDS	VOLUME CUBIC FEET	FIGURE NUMBER
	A	4-11-95	Revised & updated	CMD	BS			TYPE NO. 5
REV.	DATE	DESCRIPTION			BY			