

F



JAY R. SMITH MFG. CO.
 DIVISION OF SMITH INDUSTRIES, INC.
 POST OFFICE BOX 3237
 MONTGOMERY, ALABAMA 36109-0237 (USA)
 TEL: 334-277-8520 FAX: 334-272-7396 www.jrsmith.com



MEMBER OF:



LOCATION

NO-HUB INLET STACK FITTINGS

FUNCTION: Recommended for use with a floor mounted back outlet water closet.

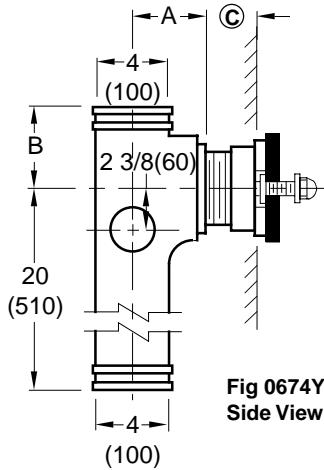

Fig 0674Y
Side View

1 1/2"(38) or 2"(51)
N.P.T. Aux. Inlet
Available, add
Suffix-N

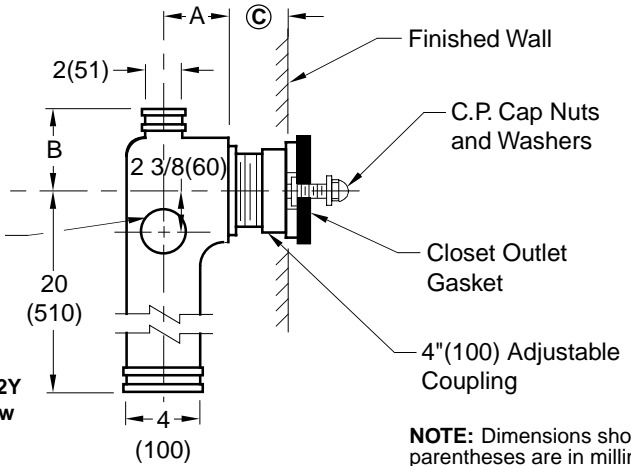
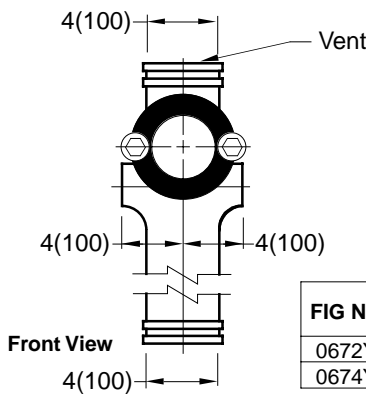

Fig. 0672Y
Side View

NOTE: Dimensions shown in parentheses are in millimeters.



Front View



Fig. 0672Y ... NO-HUB Long Barrel With 2"(51) Vent
 Fig. 0674Y ... NO-HUB Long Barrel With 4"(100) Vent

Ⓒ Dimension as regularly furnished permits a dimension of 3"(76) MIN to 4"(100) MAX. Coupling provides 1/2"(13) adjustment in either direction.
 Always specify Ⓒ dimension required.

Minimum Ⓒ dimension of 1"(25) available using special male end coupling (see type 2M below).

NOTE: Coupling should extend 5/16"(8) beyond finished wall.

NOTE: When required a 2"(51) NO-HUB Aux. inlet adapter is available specify suffix-NY

FIG NO	A	B
0672Y	4(100)	7(180)
0674Y	4(100)	5(125)

The water closet gasket regularly furnished is made of molded neoprene and designed to fit water closet outlet dimensions and configurations shown in ANSI Standard A112.19.2M-1982, Figure 13B. If gasket is not found to be compatible to fixture due to nonconformance of said fixture to ANSI A112.19.2M, then fixture manufacturer shall be consulted for a suitable gasket recommendation. Jay R. Smith assumes no liability for connections to fixtures which do not conform to these standards.

TYPICAL APPLICATION

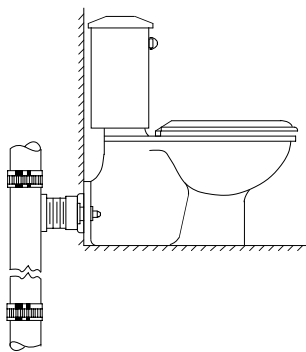

OUTLET CONNECTIONS

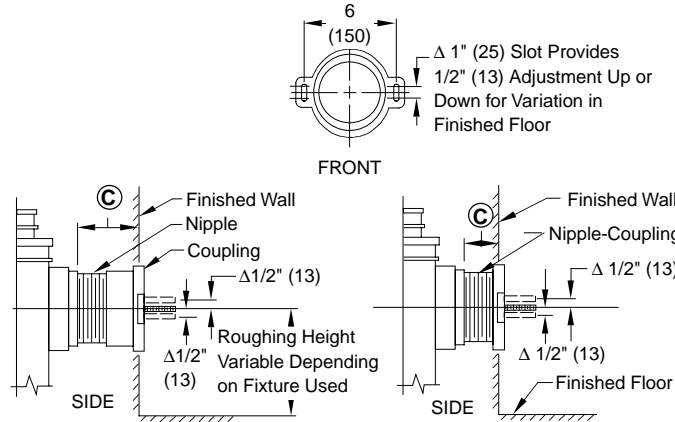

REGULARLY FURNISHED

TYPE 2M (When Specified)

NIPPLE LENGTHS AVAILABLE

NIPPLE LENGTH	MIN	Ⓒ	MAX
2 1/2 (64)	2 3/4 (70)	3 3/4 (95)	
3 1/4 (83)	3 (76)	4 1/2 (115)	
4 1/2 (115)	4 1/4 (110)	5 3/4 (145)	
5 1/4 (135)	5 (125)	6 1/2 (165)	
6 1/4 (160)	6 (150)	7 1/2 (190)	
7 (180)	6 3/4 (170)	8 1/4 (210)	
8 1/4 (210)	8 (205)	9 1/2 (240)	
10 (255)	9 3/4 (250)	11 1/4 (285)	
12 (305)	11 3/4 (300)	13 1/4 (335)	
15 (380)	14 3/4 (375)	16 1/4 (415)	
18 (455)	17 3/4 (450)	19 1/4 (490)	

* Regularly Furnished

DRAWING NUMBER
S0672Y

SIZE
A

SCALE:
NONE

DATE:
8-21-72

APPROVED BY:

CHECKED BY:
RP

DRAWN BY:
JH

0672Y, 0674Y

FIGURE NUMBER

WE CAN ASSUME NO RESPONSIBILITY FOR USE OF SUPERSEDED OR VOID DATA

DIMENSIONS ARE SUBJECT TO MANUFACTURERS TOLERANCE AND CHANGE WITHOUT NOTICE

REV.	DATE	DESCRIPTION	BY	CKD. BY
F	3-6-97	Added Millimeters	EMB	
E	6-22-94	Revised	EMB	
D	8-4-93	Submittal Update	EMB	BS

WEIGHT POUNDS	VOLUME CUBIC FEET
------------------	----------------------

FIGURE NUMBER
0672Y, 0674Y