

LABOR SAVER URINAL SUPPORTS FOR OFF-THE-FLOOR URINALS

WITH SUPPORTING STUDS AND ADJUSTABLE COUPLING FOR BLOWOUT URINALS

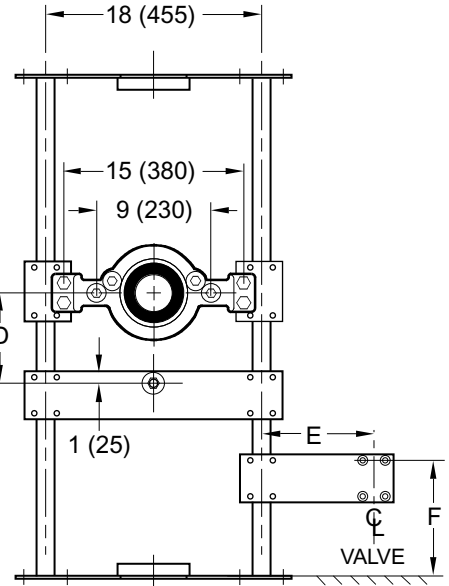
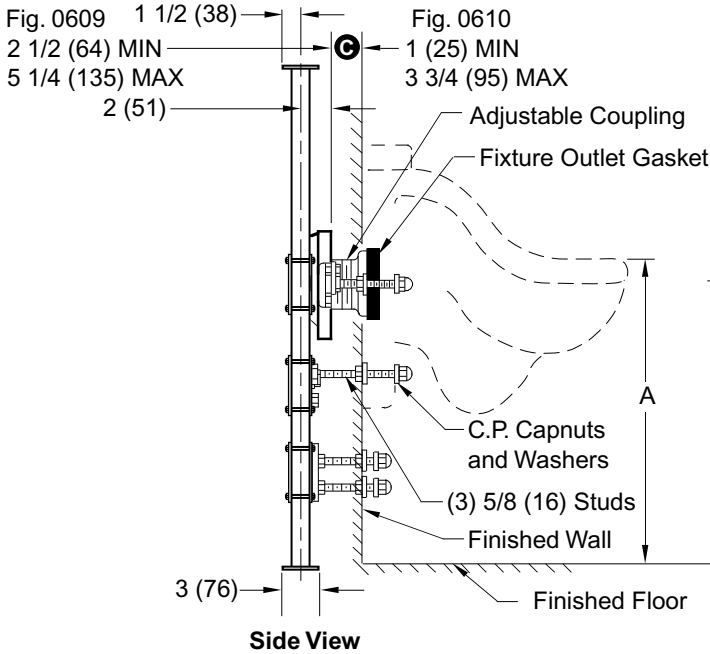

Front View

Fig. 0609 . . . 3" (75) Outlet Connection
 Fig. 0610 . . . 4" (100) Outlet Connection

NOTE: The rough-in dimensions listed on this drawing are based on current information available to Jay R. Smith by the fixture manufacturers. We recommend that you verify these dimensions with the fixture manufacturer. We will not accept responsibility for rough-in dimension changes by the fixture manufacturer.

NOTE: The water closet gasket regularly furnished is made of molded neoprene and designed to fit water closet outlet dimensions and configurations shown in ANSI Standard A112.19.2M-1982, Figure 13B. If gasket is not found to be compatible to fixture due to nonconformance of said fixture to ANSI A112.19.2M, then fixture manufacturer shall be consulted for a suitable gasket recommendation. Jay R. Smith assumes no liability for connections to fixtures which do not conform to these standards.

NOTE: Dimensions shown in parenthesis are in millimeters.

Ⓞ **NOTE:** *This dimension can be increased when fixture support is to be installed behind the wall (specify when required and wall thickness).

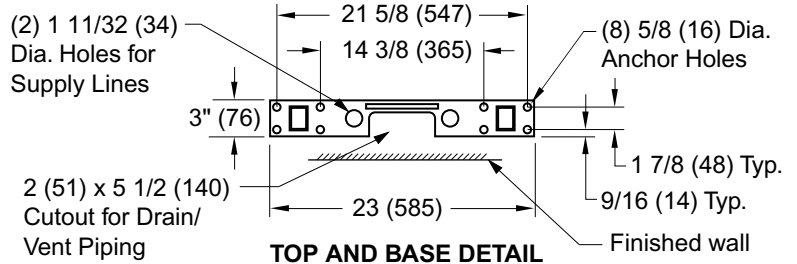

TOP AND BASE DETAIL

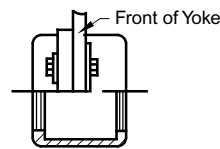

DETAIL OF COLLAR AND YOKE ASSEMBLY
 Fig. 0609
 3" (75) Outlet Connection

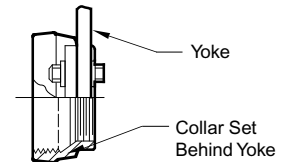

DETAIL OF COLLAR AND YOKE ASSEMBLY
 Fig. 0610
 4" (100) Outlet Connection

ROUGH-IN TABLE

FIXTURE MFG.	NAME	NUMBER	SIZE	A	B	D	E	F

REV.	DATE	DESCRIPTION	BY	CKD. BY
A	12/04/02	Revised per George Fleigel	JJ	AM

WEIGHT POUNDS	VOLUME CUBIC FEET

FIGURE NUMBER
0609, 0610 -KW

DRAWING NUMBER
 S0609, 0610 -KW

SIZE
 A

SCALE:
 NONE

DATE:
 05/28/02

APPROVED BY:
 AM

CHECKED BY:
 CR

DRAWN BY:
 JJ

FIGURE NUMBER
0609, 0610 -KW

WE CAN ASSUME NO RESPONSIBILITY FOR USE OF SUPERSEDED OR VOID DATA

DIMENSIONS ARE SUBJECT TO MANUFACTURERS TOLERANCE AND CHANGE WITHOUT NOTICE