

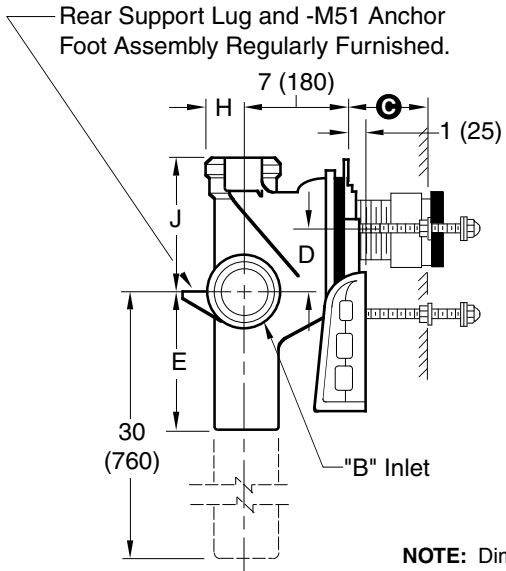
# ADJUSTABLE FIXTURE SUPPORTS

## SHALLOW ROUGH-IN TYPE FOR BLOWOUT WATER CLOSETS

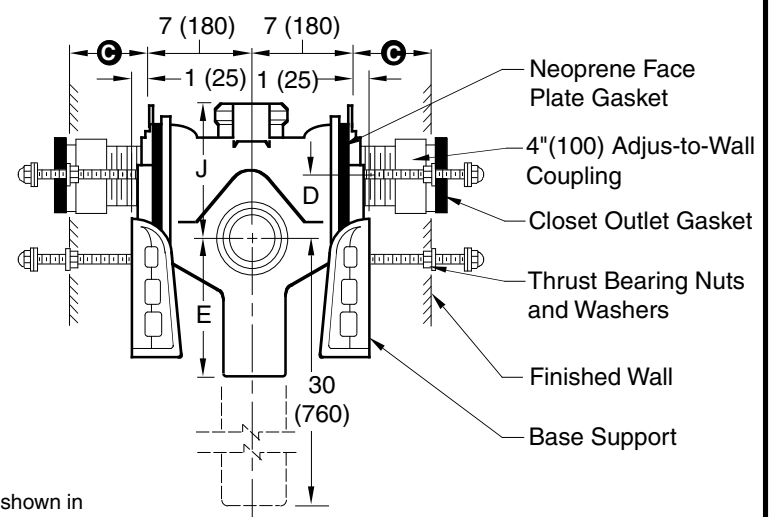
### VERTICAL FITTINGS WITH TWO SIDE HUB INLETS

**SINGLE**

**DOUBLE**

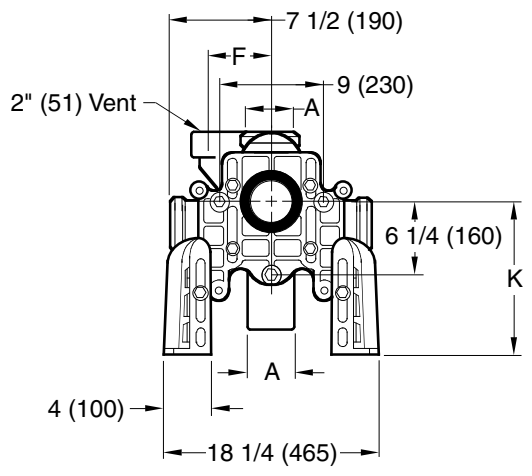


**Fig. 0350 Side View**



**Fig. 0350D Side View**

**NOTE:** Dimensions shown in parentheses are in millimeters.



**BLOWOUT Front View**

The water closet gasket regularly furnished is made of molded neoprene and designed to fit water closet outlet dimensions and configurations shown in ANSI Standard A112.19.2M-1982, Figure 13B. If gasket is not found to be compatible to fixture due to nonconformance of said fixture to ANSI A112.19.2M, then fixture manufacturer shall be consulted for a suitable gasket recommendation. Jay R. Smith assumes no liability for connections to fixtures which do not conform to these standards.

- Fig. 0350 . . . CAULK (2) INLETS
- Fig. 0350D . . . CAULK DOUBLE (2) INLETS
- Fig. 0380 . . . CAULK (2) INLETS LONG BARREL
- Fig. 0380D . . . CAULK DOUBLE (2) INLETS LONG BARREL

**NOTE:** Base support must be securely anchored to floor with four 1/2" (13) bolts provided by contractor.  
**NOTE:** When used with concealed flush valve locate face plate behind supply pipe.  
**NOTE:** See opposite side for **C** dimension and optional outlet connections.

A x B SIZE	D BLOWOUT		E	F	H	J	K BLOWOUT	
	MIN	MAX					MIN	MAX
4 x 4 (100) x (100)	2 3/4 (70)	5 1/2 (140)	10 (255)	5 1/4 (135)	3 (76)	9 (230)	10 3/4 (275)	15 3/4 (400)
5 x 4 (125) x (100)	2 7/8 (73)	5 3/4 (145)	11 1/2 (290)	6 1/2 (165)	3 1/2 (89)	11 1/2 (290)	10 3/4 (275)	15 3/4 (400)
5 x 5 (125) x (125)	2 7/8 (73)	5 3/4 (145)	11 1/2 (290)	6 1/2 (165)	3 1/2 (89)	11 1/2 (290)	10 3/4 (275)	15 3/4 (400)
6 x 4 (150) x (100)	2 3/4 (70)	5 1/2 (140)	11 1/2 (290)	6 1/4 (160)	4 (100)	11 1/2 (290)	10 3/4 (275)	15 3/4 (400)
6 x 5 (150) x (125)	2 3/4 (70)	5 1/2 (140)	11 1/2 (290)	6 1/4 (160)	4 (100)	11 1/2 (290)	10 3/4 (275)	15 3/4 (400)

DRAWING NUMBER S0350  
 SIZE A  
 SCALE: NONE  
 DATE: 12-19-89  
 APPROVED BY: McD  
 CHECKED BY: JM  
 DRAWN BY: EMB  
 DIMENSIONS ARE SUBJECT TO MANUFACTURERS TOLERANCE AND CHANGE WITHOUT NOTICE

**0350, 0380**

REV.	DATE	DESCRIPTION	BY	CKD. BY	WEIGHT POUNDS	VOLUME CUBIC FEET	FIGURE NUMBER
	1-30-98 4-25-94	Added Millimeters Submittal Update	EMB EMB	BS BS			<b>0350, 0380</b>

# MODIFICATIONS & VARIATIONS

**Ⓒ DIMENSION - ADJUS-TO-WALL TYPE OUTLET CONNECTION**

The Smith Adjus-to-Wall outlet connection provides adjustment at the face of the wall at the time the fixture is set; thus, compensating for wall construction variations. The **Ⓒ** dimension is measured from the front of the face plate to the finished wall. To properly determine the length of nipple required, deduct 1" (25) from the **Ⓒ** dimension. When the **Ⓒ** dimension exceeds 7" (180), the -M40 Wide Pipe Chase Support is recommended. The Adjus-to-Wall coupling will provide 1/2" (13) horizontal adjustment in either direction with the coupling extended 5/16" (8) past face of the finished wall.

**Ⓒ** dimension = 4" (100) (regularly furnished) consisting of nipple and adjus-to-wall coupling permitting adjustment from 3" (76) min. to 4" (100) max.

\*ABS (Regularly Furnished) other length PVC.

**NIPPLE LENGTHS AVAILABLE**

LENGTH	MIN	Ⓒ	MAX
2 1/2 (64)	2 1/4 (57)	3 1/4 (83)	
*3 1/4 (83)	3 (76)	4 (100)	
*8 1/4 (210)	8 (205)	9 (230)	
10 (255)	9 3/4 (250)	10 3/4 (275)	
12 (305)	11 3/4 (300)	12 3/4 (325)	
15 (380)	14 3/4 (376)	15 3/4 (400)	
18 (455)	17 3/4 (450)	18 3/4 (475)	

NOTE: When nipple lengths between 3 1/4" (83) and 8 1/4" (210) are specified, the 8 1/4" (210) nipple will be supplied. Nipple must be cut to specified length by others.

## RECOMMENDED SETTING OF CLOSET OUTLET CONNECTION AND FIXTURE STUDS

Manufacturers have slight differences in the depth of the closet horn and flange thickness of their closets. Usually the fixture support closet connection should extend 5/16" (8) beyond face of finished wall (Dimension "R") and the fixture studs 2 1/4" (57) (Dimension "X"). For exact dimensions please use the formulas below.

**DETAIL A** Formula for "R" is:  $S + 1/16" (2) - D = R$   
 S = Depth of closet horn  
 1/16" (2) = Distance closet is to set away from finished wall.  
 D = 1/2" (13) for felt gasket and 3/8" (10) for neoprene gasket.  
 R = Distance coupling should extend beyond finished wall.  
 NOTE: When the fixture is installed, closet gasket must be compressed sufficiently to assure a gas and water-tight seal.

**DETAIL B** Formula for "X" is:  $Y + 1/16" (2) + 9/16" (14) = X$   
 Y = Thickness of closet wall flange.  
 1/16" (2) = Distance closet is to set away from finished wall.  
 X = Distance supporting stud should extend beyond finished wall.  
 NOTE: Bearing nuts and washers must be set to take full loading from the fixture allowing 1/16" (2) clearance between fixture and wall.

**NOTE:** Dimensions shown in parentheses are in millimeters.

**Exposed Flush Valve** 4 3/4" (120) 10 1/2 (265) MIN 16 (405) MAX 10 (405) MAX

11 1/2" (290) Standard

Water Closet

Provides support and alignment for the supply pipe to an exposed flush valve; must be specified for either 1" (25) copper tube or 1" (25) iron pipe.

**SUFFIX -M12 EXPOSED FLUSH VALVE SUPPLY SUPPORT**

**M40 WATER CLOSET SUPPORT FOR WIDE PIPE CHASE (USE WHEN Ⓒ DIMENSION EXCEEDS 7" (180))**

**CONCEALED FLUSH VALVES**

A concealed flush valve when used with a blowout water closet support will not clear the face plate. Therefore 4 1/2" (115) to 6 1/2" (165) is required from back of wall to face plate to permit the installation of the concealed flush valve piping.

**SUFFIX -M13 TILING FRAME - POLYSTYRENE**

FIGURE NUMBER	C	12-10-03	Revised Notes Added Millimeters Submittal Update	RN	CL	WEIGHT POUNDS	VOLUME CUBIC FEET	FIGURE NUMBER <b>0200/0300 Series Back Sheet</b>
	B	6-1-95		EMB	BS			
REV.	DATE	DESCRIPTION	BY	CKD. BY				

DRAWING NUMBER: S0200BS  
 SIZE: A  
 SCALE: NONE  
 DATE: 2-28-86  
 APPROVED BY: JD  
 CHECKED BY: CR  
 DRAWN BY: VGD  
 0200/0300 Series Back Sheet  
 DIMENSIONS ARE SUBJECT TO MANUFACTURERS TOLERANCE AND CHANGE WITHOUT NOTICE  
 WE CAN ASSUME NO RESPONSIBILITY FOR USE OF SUPERSEDED OR VOID DATA