



JAY R. SMITH MFG. CO.
 DIVISION OF SMITH INDUSTRIES, INC.
 POST OFFICE BOX 3237
 MONTGOMERY, ALABAMA 36109-0237 (USA)
 TEL: 334-277-8520 FAX: 334-272-7396 www.jrsmith.com



MEMBER OF:

LOCATION

ADJUSTABLE FIXTURE SUPPORTS FOR SIPHON JET WATER CLOSETS

NO-HUB HORIZONTAL FITTINGS EXTRA HEAVY DUTY - 750 LBS.

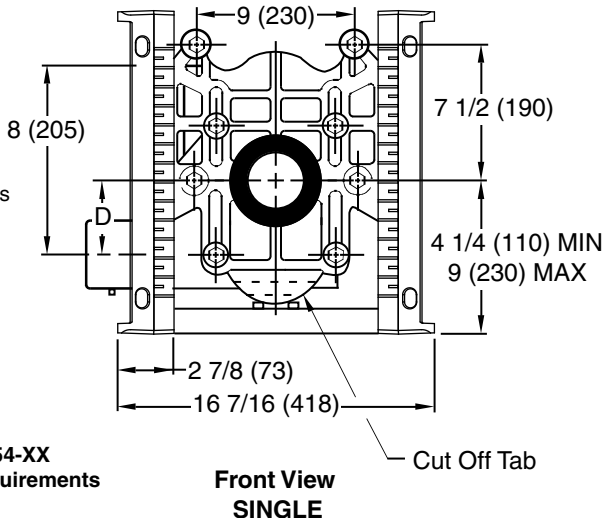
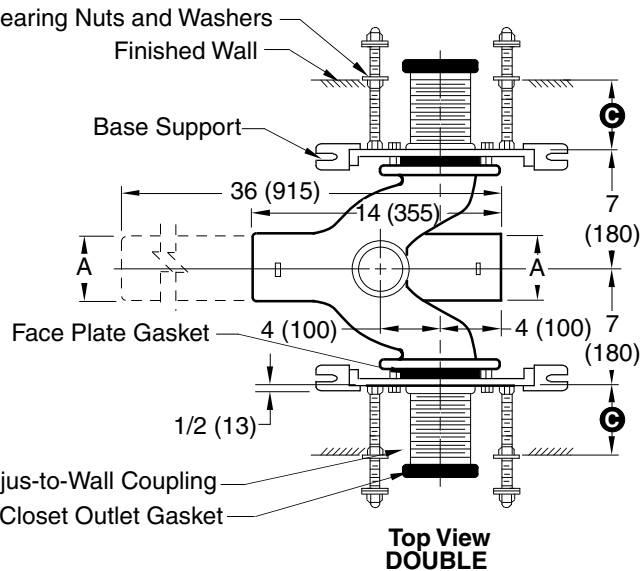
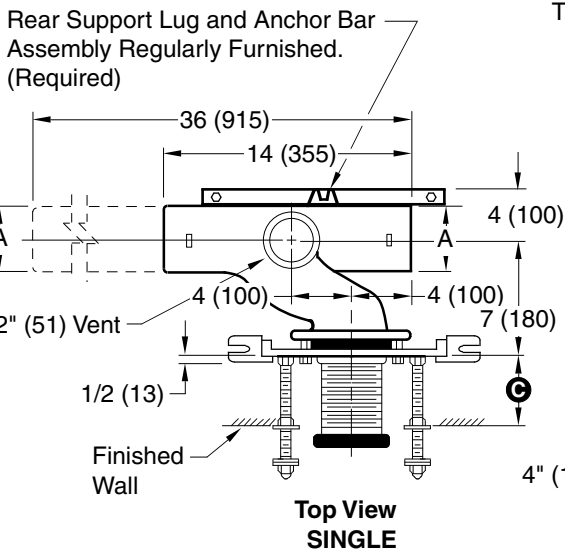

NOTE: Base support must be securely anchored to floor with 1/2" (13) anchors able to withstand a pull-out force of 500 lbs (227 kg). The rear anchor bar must be securely anchored to floor with 1/2" (13) anchors able to withstand a pull-out force of 1000 lbs (454 kg). Pull-out forces are calculated values, no safety factor has been applied.

NOTE: Dimensions shown in parentheses are in millimeters.

A SIZE	D	
	MIN	MAX
4 (100)	5/8 (16)	3 1/8 (79)
5 (125)	5/8 (16)	3 1/8 (79)

NOTE: When nipple lengths between 3 1/4" (83) and 9 3/4" (247) are specified, the 10" (255) nipple will be supplied. The threaded end of nipple must be cut to specified length by others.

Jay R. Smith 0210Y or 0220Y-M58-M54-XX complies with and/or exceeds all requirements of ASME A112.6.1M up to 750 lbs.

LENGTH	MIN.	MAX.
10(255)	8 3/4"(222)	9 3/4"(247)

- Fig. 0210LY-M58-M54-XX . . . NO-HUB Left Hand
- Fig. 0210RY-M58-M54-XX . . . NO-HUB Right Hand
- Fig. 0210DY-M58-M54-XX . . . NO-HUB Double
- Fig. 0220LY-M58-M54-XX . . . NO-HUB Left Hand Long Barrel
- Fig. 0220RY-M58-M54-XX . . . NO-HUB Right Hand Long Barrel
- Fig. 0220DY-M58-M54-XX . . . NO-HUB Double Long Barrel

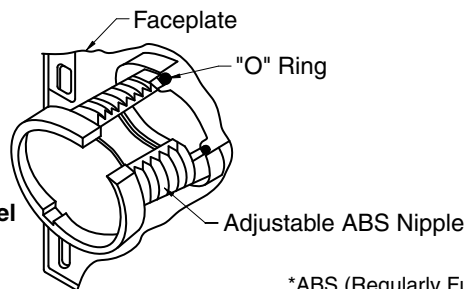

*ABS (Regularly Furnished).

DRAWING NUMBER
S0210Y, 0220Y-M58-M54-XX

SIZE
A

SCALE:
NONE

DATE:
10/09/07

APPROVED BY:
CL

CHECKED BY:
CL

DRAWN BY:
JJ

0210Y, 0220Y-M58-M54-XX

FIGURE NUMBER

WE CAN ASSUME NO RESPONSIBILITY FOR USE OF SUPERSEDED OR VOID DATA

DIMENSIONS ARE SUBJECT TO MANUFACTURERS TOLERANCE AND CHANGE WITHOUT NOTICE

REV.	DATE	DESCRIPTION	BY	CKD. BY
A	5-13-08	Revised Note	TBW	CL

WEIGHT POUNDS	VOLUME CUBIC FEET	FIGURE NUMBER
		0210Y, 0220Y -M58-M54-XX