

E



JAY R. SMITH MFG. CO.®
 DIVISION OF SMITH INDUSTRIES, INC.
 POST OFFICE BOX 3237
 MONTGOMERY, ALABAMA 36109-0237 (USA)
 TEL: 334-277-8520 FAX: 334-272-7396 www.jrsmith.com



MEMBER OF:



LOCATION

CAULK FERRULE CLEANOUTS WITH FRAME AND COVER

LEAD SEAL PLUG WITH ROUND FRAME AND COVER

FUNCTION: Used to cover cleanout plugs concealed in walls. Round design eliminates necessity for lining up with adjacent floors, ceilings, moldings, etc. The anchoring lugs provide easy means for securing the frame to the wall construction. The face-of-wall cover (4432) is for tile, masonry, or dry wall construction and is usually installed on an opening provided in the finished wall. The flush-with-wall cover (4433) is for plaster or wet wall construction and is installed during wall construction.

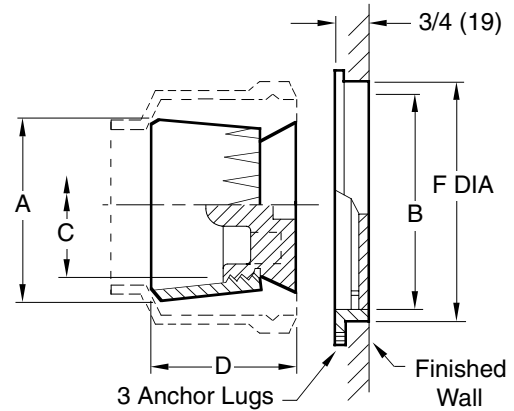
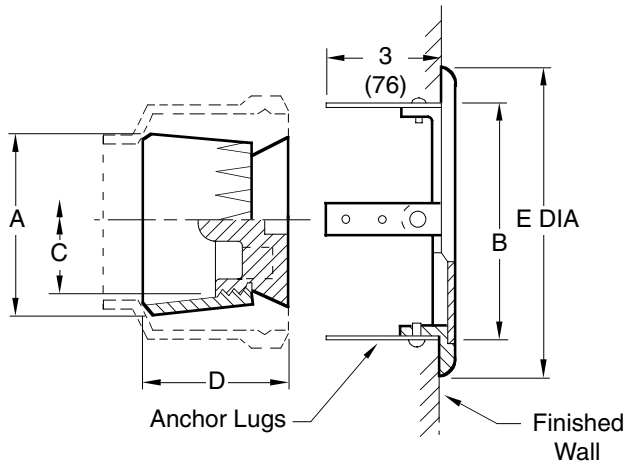

FIG. 4432C FACE-OF-WALL COVER

FIG. 4433C FLUSH-WITH-WALL COVER

A SIZE	B OPENING	C SIZE	D	E DIA	F DIA
02 (50)	4 (100)	1 1/2 (38)	2 1/2 (64)	6 (150)	4 1/2 (115)
03 (80)	5 1/2 (140)	2 1/2 (64)	2 3/4 (70)	7 (180)	5 3/4 (145)
04 (100)	6 (150)	3 1/2 (89)	3 (76)	7 1/2 (190)	6 1/2 (165)
05 (125)	6 (150)	4 1/2 (115)	3 (76)	7 1/2 (190)	6 1/2 (165)
06 (150)	8 (205)	5 1/2 (140)	3 (76)	10 (255)	8 1/2 (215)
08 (200)	10* (255)	7 1/2 (190)	3 1/2 (89)	-	10 1/2 (265)

*Not available for 4432

NOTE: Dimensions shown in parentheses are in millimeters.

REGULARLY FURNISHED:

Duco Cast Iron Caulk Ferrule with Cast Iron Lead Seal Plug. Chrome Plated Bronze Round Frame and Secured Cover. Type of Cover as Indicated by Figure Number Selected.

VARIATIONS:

Vandal Proof Screws -U
 "T" Handle Plug -TP
 Plug Tapped 1/4"(6)-20 Thread

OPTIONAL MATERIALS:

Cast Bronze Body -BB
 Cast Bronze Plug -BP
 Nickel Bronze Frame and Cover -NB
 Polished Bronze Frame and Cover -PB

DRAWING NUMBER
S4432SIZE
ASCALE:
NONEDATE:
2-16-70APPROVED BY:
JMCHECKED BY:
BHDRAWN BY:
RK

4432, 4433

FIGURE NUMBER

WE CAN ASSUME NO RESPONSIBILITY FOR USE OF SUPERSEDED OR VOID DATA

DIMENSIONS ARE SUBJECT TO MANUFACTURERS TOLERANCE AND CHANGE WITHOUT NOTICE

REV.	DATE	DESCRIPTION	BY	CKD. BY	WEIGHT POUNDS	VOLUME CUBIC FEET	FIGURE NUMBER
E	8-11-97	Chg'd Var. & Opt. Mat .	EMB	BS			4432, 4433
D	1-11-96	Added Millimeters	EMB	BS			
C	7-27-94	Revised	EMB	BS			
B	7-28-93	Update Format	TWK	BS			