

FLOOR CLEANOUTS FOR UNFINISHED FLOORS

CLEANOUT BODIES WITH CLOSURE PLUG

FUNCTION: Used where extension type cleanout is required. Not recommended for installation in floors or areas subjected to traffic unless access cover is provided.

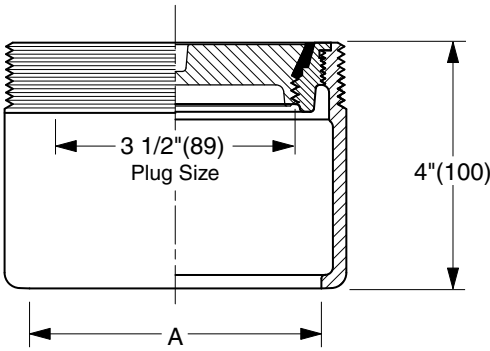

INSIDE CAULK OUTLET

"A" (Pipe Size) = 02(50), 03(75) or 04(100)

- Fig. 4285C.....Gasket Seal - ABS Plug
- Fig. 4286C.....Gasket Seal - Bronze Plug
- Fig. 4288C.....Taper Thread - Bronze Plug
- Fig. 4289C.....Taper Thread - ABS Plug

NOTE: Dimensions shown in parentheses are in millimeters.

REGULARLY FURNISHED:
 Duco Cast Iron Cleanout with Closure Plug Type as Indicated By Figure Number Selected.

- VARIATIONS:**
- Flashing Flange -F
 - Flange with Flashing Clamp -F-C

OPTIONAL MATERIALS:

- Galvanized Cast Iron -G

4285 SERIES

WE CAN ASSUME NO RESPONSIBILITY FOR USE OF SUPERSEDED OR VOID DATA

FIGURE NUMBER	A	6-25-02	Revised Dwg.	RN	CL	WEIGHT POUNDS	VOLUME CUBIC FEET	FIGURE NUMBER
REV.	DATE	DESCRIPTION	BY	CKD. BY			4285 SERIES	