

K



JAY R. SMITH MFG. CO.
 DIVISION OF SMITH INDUSTRIES, INC.
 POST OFFICE BOX 3237
 MONTGOMERY, ALABAMA 36109-0237 (USA)
 TEL: 334-277-8520 FAX: 334-272-7396 www.jrsmith.com



MEMBER OF:

LOCATION

DRAWING NUMBER
S4200

SIZE
A

SCALE:
NONE

DATE:
2-16-70

APPROVED BY:
JM

CHECKED BY:
BH

DRAWN BY:
RK

4200 SERIES

FIGURE NUMBER

DIMENSIONS ARE SUBJECT TO MANUFACTURERS TOLERANCE AND CHANGE WITHOUT NOTICE

TERRAZZO FLOOR CLEANOUTS WITH "TWIS-TO-FLOOR®" ADJUSTABLE TOPS

SQUARE NICKEL BRONZE TOP WITH TERRAZZO RECESS

FUNCTION: Used in terrazzo and similar poured floors bearing foot and medium load wheeled traffic. The recess is filled with the floor material, presenting an unobtrusive appearance. Lock-in design firmly holds floor material in recess.

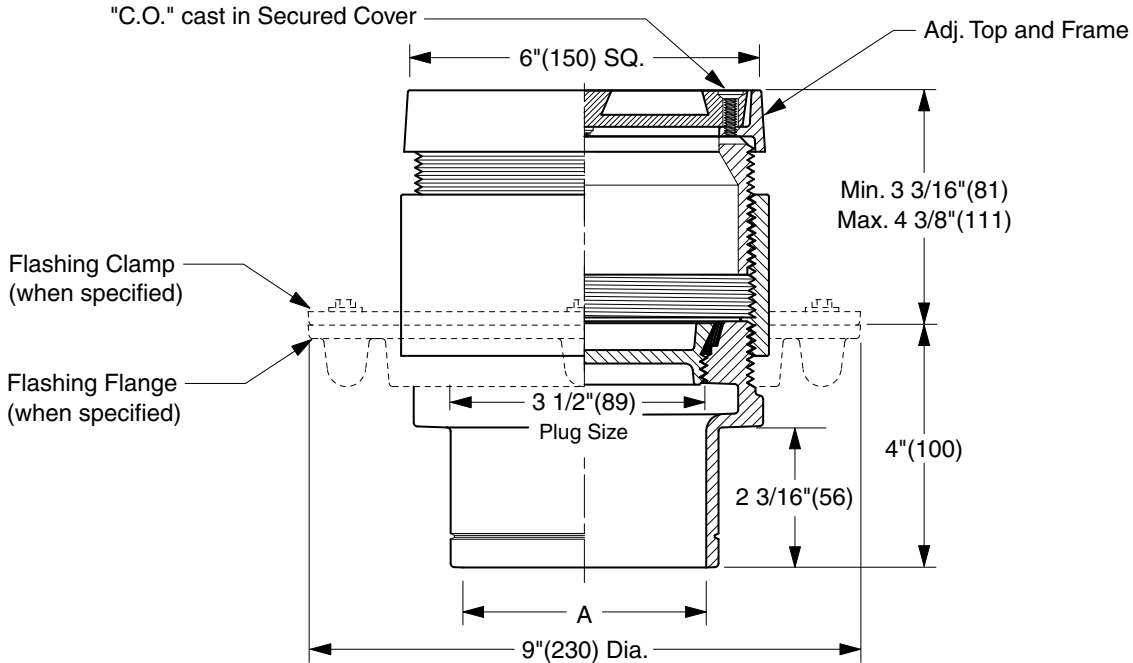

"A" (Pipe Size) = 02(50), 03(75), 04(100) or 05(125)

- Fig. 4200S.....Gasket Seal - ABS Plug
- Fig. 4201S.....Gasket Seal - Bronze Plug
- Fig. 4203S.....Taper Thread - Bronze Plug
- Fig. 4204S.....Taper Thread - ABS Plug

(Twis-to-Floor® design shown with gasketed plug.)

NOTE: Dimensions shown in parentheses are in millimeters.

REGULARLY FURNISHED:

Duco Cast Iron Cleanout with Square Adjustable Secured Nickel Bronze Top with 1/2"(13) Terrazzo Recess. Closure Plug Type as Indicated By Figure Number Selected.

VARIATIONS:

- Flashing Flange -F
- Flange with Flashing Clamp -F-C
- Vandal Proof Top -U

OPTIONAL MATERIALS:

- Galvanized Cast Iron -G
- Polished Bronze Top -PB

K J H	07/29/02 05/07/01 10/26/00	Corrected Clamp & Flange view Edited Outlet Text New design	JJ JJ JJ	CL CL BS
REV.	DATE	DESCRIPTION	BY	CKD. BY

WEIGHT POUNDS	VOLUME CUBIC FEET	FIGURE NUMBER 4200 SERIES
------------------	----------------------	-------------------------------------



LOCATION

TERRAZZO FLOOR CLEANOUTS WITH "TWIS-TO-FLOOR®" ADJUSTABLE TOPS

SQUARE NICKEL BRONZE TOP WITH TERRAZZO RECESS

FUNCTION: Used in terrazzo and similar poured floors bearing foot and medium load wheeled traffic. The recess is filled with the floor material, presenting an unobtrusive appearance. Lock-in design firmly holds floor material in recess.

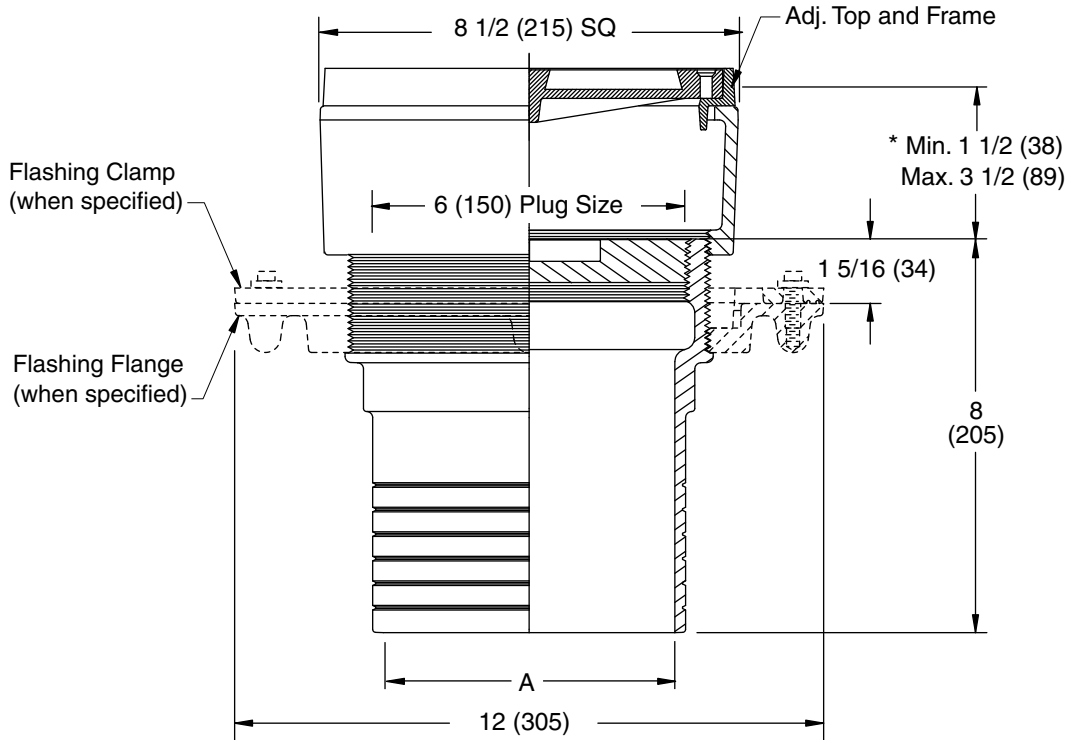

SPIGOT OUTLET ▲

"A" (Pipe Size) = 06(150) & 08(200)

▲ Sized for Service Weight and/or NO-HUB.

* When Flange-F is specified Min. 1 1/2 (38) becomes 2 (51)

"TWIS-TO-FLOOR®" ADJUSTMENT

SPIGOT OUTLET ▲

Fig. 4203S.....Taper Thread - Bronze Plug

REGULARLY FURNISHED:

Duco Cast Iron Cleanout with Taper Thread Bronze Plug and Square Adjustable Secured Nickel Bronze Top with 1/2 (13) Terrazzo Recess.

VARIATIONS:

- Flashing Flange -F
- Flange with Flashing Clamp -F-C
- Vandal Proof Top -U

OPTIONAL MATERIALS:

- Galvanized Cast Iron -G
- Polished Bronze Top -PB

NOTE: Dimensions shown in parentheses are in millimeters.

DRAWING NUMBER
S4200BS

SIZE
A

SCALE:
NONE

DATE:
5-5-06

APPROVED BY:
CEL

CHECKED BY:
CL

DRAWN BY:
RN

FIGURE NUMBER
4203

DIMENSIONS ARE SUBJECT TO MANUFACTURERS TOLERANCE AND CHANGE WITHOUT NOTICE

REV.	DATE	DESCRIPTION	BY	CKD. BY

WEIGHT POUNDS	VOLUME CUBIC FEET

FIGURE NUMBER 4203
