



JAY R. SMITH CO.

PLUMBING & DRAINAGE PRODUCTS
 959 Alness Street, North York, Ontario M3J 2J1
 TEL: (416) 736-9610 FAX: (416) 736-3789

LOCATION

DRAWING NUMBER
SSQ-4-1753-A w/3580-CAN

SIZE
A

SCALE:
NONE

DATE:
09/11/07

APPROVED BY:
AM

CHECKED BY:
AM

DRAWN BY:
JJ

SQ-4-1753-A w/3580-CAN

WE CAN ASSUME NO RESPONSIBILITY FOR USE OF SUPERSEDED OR VOID DATA

ADJUSTABLE FUNNEL DRAIN

FOR NON-MEMBRANE FLOORS

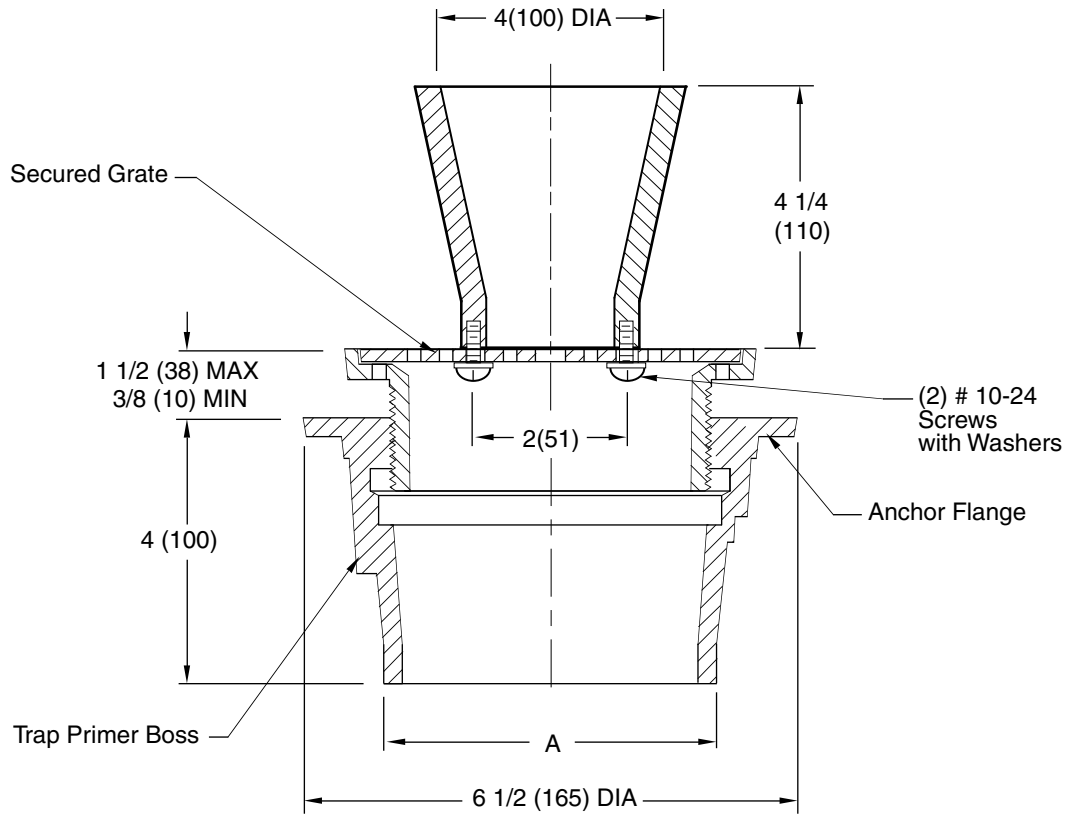

NO-HUB OUTLET

A (Pipe Size) = 02 (50), 03 (75), 04 (100)

REGULARLY FURNISHED:

Duco Cast Iron Body
 with 5" Adjustable Cast Iron
 Strainer Head and Grate,
 with 4" Dia. Funnel Assemble.

VARIATIONS:

- Vandal Proof Screws -U
- 1/2" Trap Primer Connection P-050

OPTIONAL MATERIAL:

- Nickel Bronze -NB TOP
- Stainless Steel -SS TOP
- A.R.C. Cast Iron -ARC

NOTE: Dimensions shown in parentheses are in millimeters.

REV.	DATE	DESCRIPTION	BY	CKD. BY

WEIGHT POUNDS	VOLUME CUBIC FEET

FIGURE NUMBER
SQ-4-1753-A
w/3580-CAN