



JAY R. SMITH inc.

PLUMBING & DRAINAGE PRODUCTS

959 Alness Street, North York, Ontario M3J 2J1

TEL: (416) 736-9610 FAX: (416) 736-3789

LOCATION

B

DRAWING NUMBER
SSQ-2-2647-CAN

SIZE
A

SCALE:
NONE

DATE:
4-9-01

APPROVED BY:
BS

CHECKED BY:
WMS

DRAWN BY:
RN

SQ-2-2647

FIGURE NUMBER

WE CAN ASSUME NO RESPONSIBILITY FOR USE OF SUPERSEDED OR VOID DATA

DIMENSIONS ARE SUBJECT TO MANUFACTURERS TOLERANCE AND CHANGE WITHOUT NOTICE

EXTRA HEAVY DUTY FLOOR DRAIN

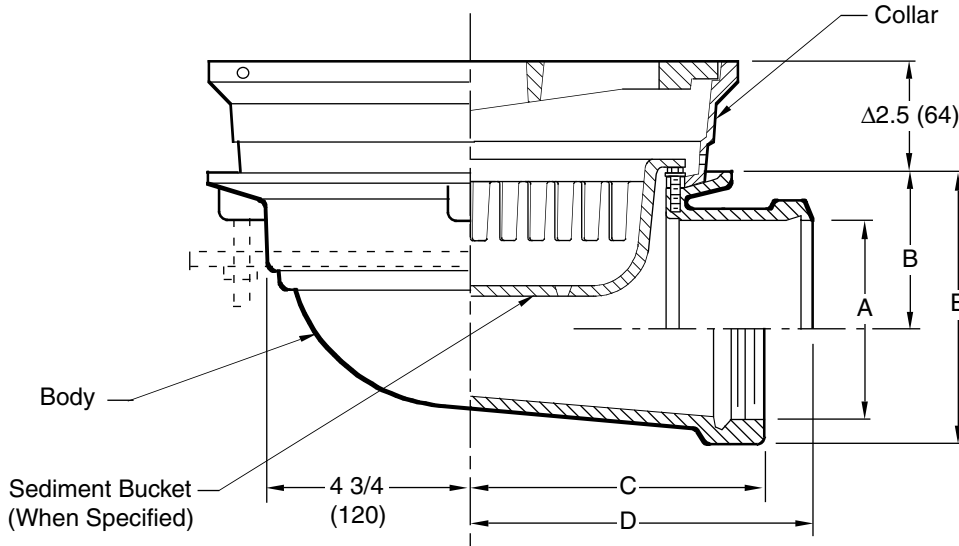
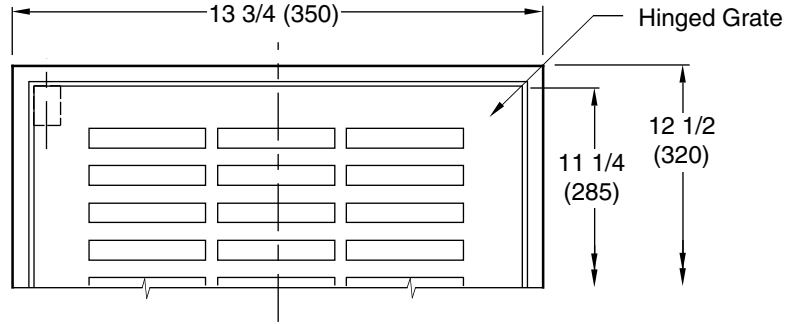

ΔAdd 5/32 (4) when NB or PB Top is specified

*NOTE: 02 thru 04 size use Conversion Collar.

A SIZE	*02 (50)	*03 (75)	*04 (100)	05 (125)	06 (150)
B	4 1/2 (115)	4 (100)	3 1/2 (89)	05 (125)	06 (150)
C	6 (150)	6 (150)	6 (150)	6 7/8 (175)	6 5/8 (168)
D	7 1/4 (185)	7 1/2 (190)	7 3/4 (195)	7 3/4 (195)	7 3/4 (195)
E	6 1/2 (165)	6 5/8 (168)	6 5/8 (168)	9 1/4 (235)	10 15/16 (235)

REGULARLY FURNISHED:
 Duco Cast Iron Body and Flashing
 Collar with Cast Iron Hinged Bar Grate.

- VARIATIONS:**
- Trap Primer Connection -P
 - Locking Grate
 - Sediment Bucket -B
 - Secured Grate -SG
 - Vandal Proof Grate -VP
 - Less Grate -10
 - Secondary Strainer -FBS

- OPTIONAL MATERIALS:**
- Galvanized -G
 - Nickel Bronze Top -NB
 - Polished Bronze Top -PB
 - Ductile Iron Grate -M
 - Stainless Steel Top -SS

REV.	DATE	DESCRIPTION	BY	CKD. BY
B	6-27-08	Rev. Opt. Materials	TBW	CL
A	5-20-04	Rev. Chart	RN	AL

WEIGHT POUNDS	VOLUME CUBIC FEET

FIGURE NUMBER
SQ-2-2647