



JAY R. SMITH CO.
PLUMBING & DRAINAGE PRODUCTS
 959 Alness Street, North York, Ontario M3J 2J1
 TEL: (416) 736-9610 FAX: (416) 736-3789

LOCATION

DRAWING NUMBER: **SSQ-2-1717-52 CAN**
 SIZE: **A**
 SCALE: **NONE**
 DATE: **4-22-08**
 APPROVED BY: **CEL**
 CHECKED BY: **CL**
 DRAWN BY: **RN**
SSQ-2-1717-52
 DIMENSIONS ARE SUBJECT TO MANUFACTURERS TOLERANCE AND CHANGE WITHOUT NOTICE

WE CAN ASSUME NO RESPONSIBILITY FOR USE OF SUPERSEDED OR VOID DATA

EXTRA HEAVY DUTY FLOOR DRAIN

FREE AREA
 52 SQ. IN.
 (335) SQ CM

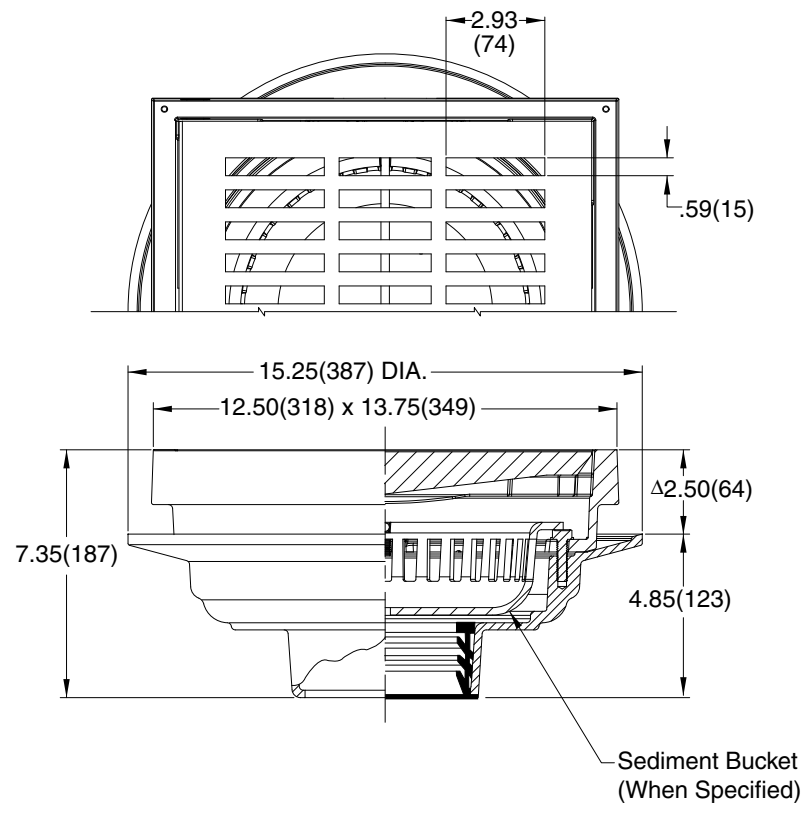

OUTLET	SIZE A
Caulk (Reg.) & NO-HUB	02(50), 03(75), 04(100), 05(127), 06(152)

ΔAdd 5/32 when NB or PB Top is specified

REGULARLY FURNISHED:
 Duco Cast Iron Body and Flashing Collar with Ductile Iron Hinged Bar Grate.

- VARIATIONS:**
- Sediment Bucket -B
 - Secured Grate -SG
 - Vandal Proof Grate -VP
 - Less Grate -10
 - Secondary Strainer -FBS

- OPTIONAL MATERIALS:**
- Galvanized -G
 - Nickel Bronze Top -NB
 - Polished Bronze Top -PB

REV.	DATE	DESCRIPTION	BY	CKD. BY

WEIGHT POUNDS
 VOLUME CUBIC FEET

FIGURE NUMBER
SQ-2-1717-52