



# JAY R. SMITH CO.

PLUMBING & DRAINAGE PRODUCTS

959 Alness Street, North York, Ontario M3J 2J1

TEL: (416) 736-9610 FAX: (416) 736-3789

LOCATION

M

DRAWING NUMBER  
S5609QT-CAN

SIZE  
A

SCALE:  
NONE

DATE:  
1-2-90

APPROVED BY:  
SJM

CHECKED BY:  
SB

DRAWN BY:  
EMB

FIGURE NUMBER  
**5609QT-CAN**

WE CAN ASSUME NO RESPONSIBILITY FOR USE OF SUPERSEDED OR VOID DATA

DIMENSIONS ARE SUBJECT TO MANUFACTURERS TOLERANCE AND CHANGE WITHOUT NOTICE

## QUARTERHORSE 1/4 TURN NON FREEZE WALL HYDRANT WITH INTEGRAL VACUUM BREAKER

### EXPOSED HOSE CONNECTION

**FUNCTION:** For installation in interior or exterior building walls where an exposed hose connection is acceptable. Provides positive non-freeze protection and features an integral vacuum breaker. Adaptable to all types of wall construction.

1/4 Turn of the Key Allows Full Flow to be Obtained

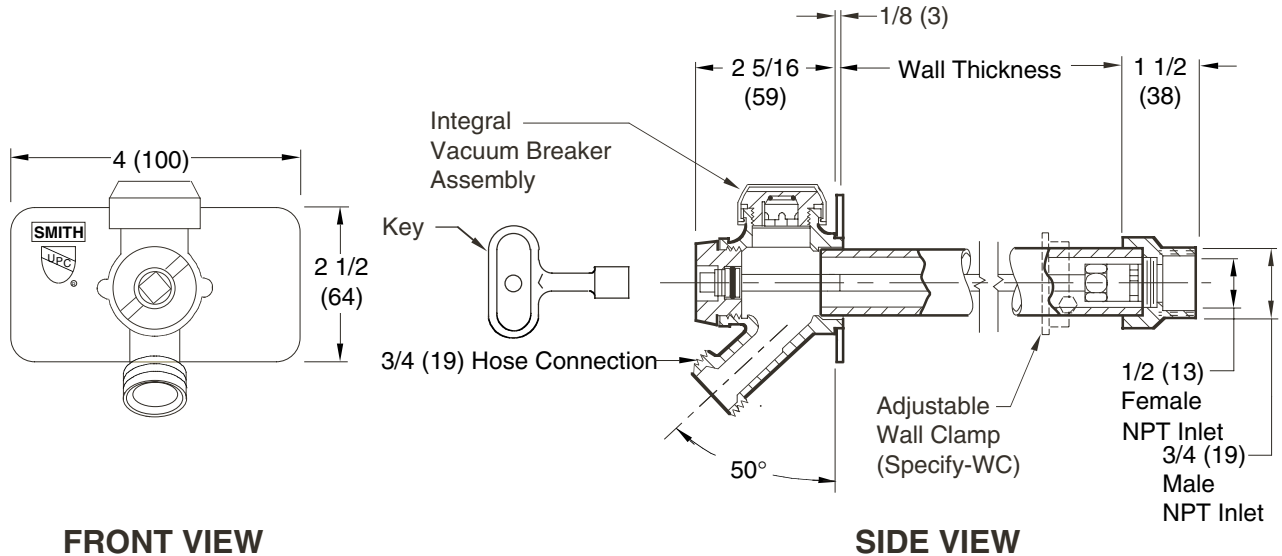

FIG. 5609QT

Seepage of a small amount of water may occur from the vacuum breaker upon the initial opening of this hydrant. This is normal operation.

#### REGULARLY FURNISHED:

Bronze Nickel Plated Quarter Turn Non-Freeze Hydrant with 3/4" (19) Hose Connection, Backer Plate, Integral Vacuum Breaker with Vandal Resistant Cap and "T" Handle Key.

#### VARIATIONS:

- Adjustable Wall Clamp -WC
- 1" (25) Hose Connection -HC1
- 1" (25) Male NPT Inlet Connection -IC1
- Wheel Handle -WH

#### OPTIONAL MATERIALS:

- Chrome Plated -CP
- Chrome Plated Backer Plate -BPCP
- Polished Bronze -PB
- Polished Bronze Backer Plate -BPPB

\* Add 3/4" (19) to Overall Length When Specified

- NOTES:**
1. Recommended wall opening 2(51) x 2(51). Hydrant shall be in the vertical position only, the hose connection must be on the bottom.
  2. When ordering, specify wall thickness in 02"(51) increment as follows: 04(100), 06(150), 08(205), 10(255), 12(305), 14(355), 16(405), 18(455), 20(510), 22(560) or 24"(610). When wall clamp -WC is desired, increase wall thickness dimension by 2"(51).
  3. All Jay R. Smith hydrants are manufactured with "NO-LEAD" brazing rings and USDA approved lubricants.

**NOTE:** Dimensions shown in parentheses are in millimeters.

PATENTED

|      |          |                   |     |         |
|------|----------|-------------------|-----|---------|
| M    | 3-26-99  | Revised           | CMD | CL      |
| L    | 7-6-95   | Added Millimeters | EMB | BS      |
| K    | 8-3-94   | Revised           | EMB | BS      |
| J    | 9-21-93  | Submittal Update  | EMB | BS      |
| H    | 11-30-92 | Removed ASSE Logo | TWK | McD     |
| REV. | DATE     | DESCRIPTION       | BY  | CKD. BY |

|                  |                      |                                    |
|------------------|----------------------|------------------------------------|
| WEIGHT<br>POUNDS | VOLUME<br>CUBIC FEET | FIGURE NUMBER<br><b>5609QT-CAN</b> |
|------------------|----------------------|------------------------------------|

SEE REVERSE SIDE

H



# JAY R. SMITH CO.

PLUMBING & DRAINAGE PRODUCTS

959 Alness Street, North York, Ontario M3J 2J1

TEL: (416) 736-9610 FAX: (416) 736-3789

LOCATION

## HYDRANT PARTS LIST

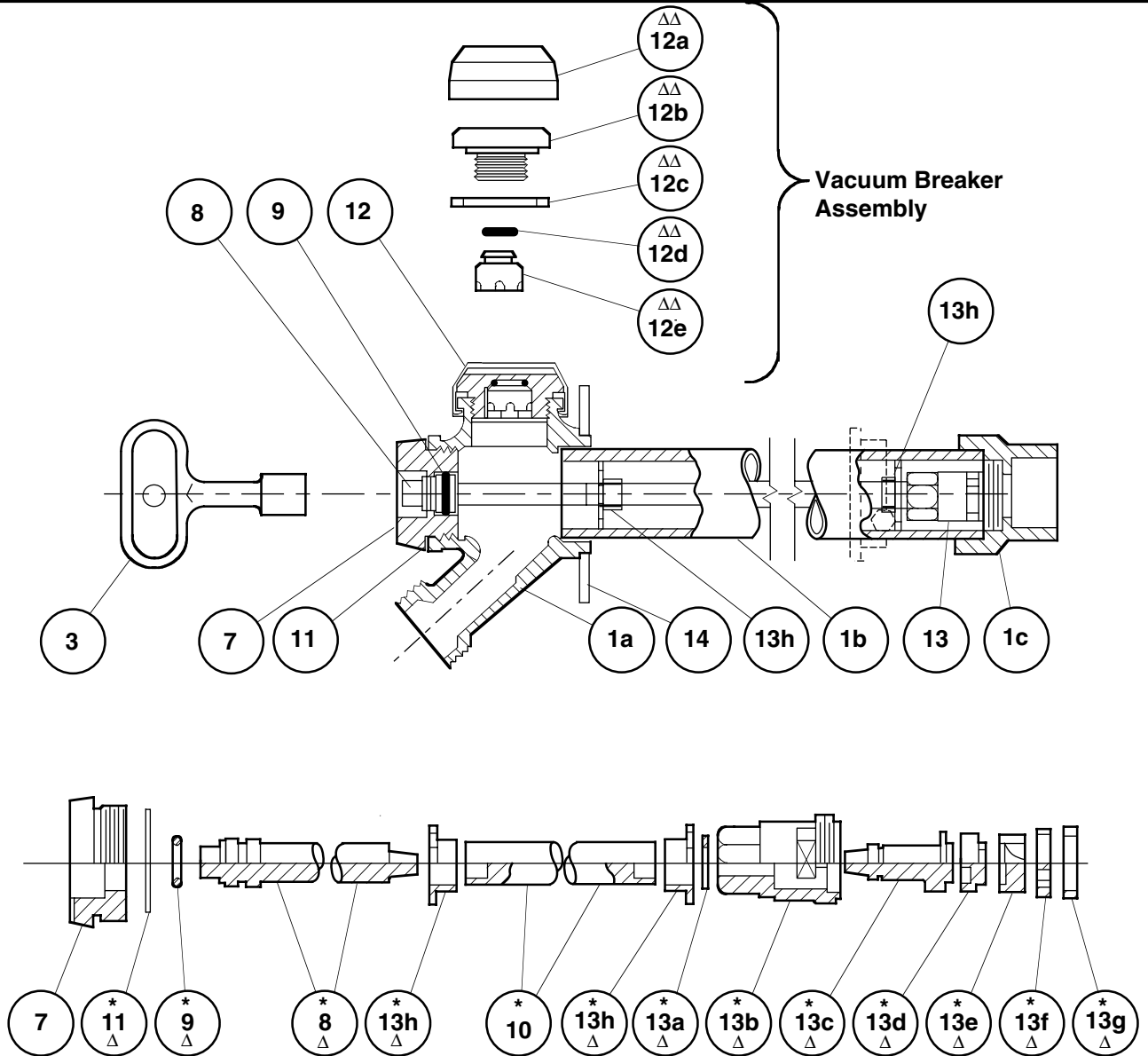

WE CAN ASSUME NO RESPONSIBILITY FOR USE OF SUPERSEDED OR VOID DATA

DIMENSIONS ARE SUBJECT TO MANUFACTURERS TOLERANCE AND CHANGE WITHOUT NOTICE

DRAWING NUMBER  
5609QTBS-CAN

SIZE  
A

SCALE:  
NONE

DATE:  
1-3-90

APPROVED BY:  
TD

CHECKED BY:  
BS

DRAWN BY:  
EMB

FIGURE NUMBER  
5609QT-BS-CAN

- Δ These Replacement Parts Available in HPRK-7
- ΔΔ These Replacement Parts Available in HPRK-7VB
- \* These Parts Accessible from Face of Hydrant by Removing Face Nut.

| HYDRANT PARTS LIST |                      |     |                         |     |                       |
|--------------------|----------------------|-----|-------------------------|-----|-----------------------|
| NO.                | DESCRIPTION          | NO. | DESCRIPTION             | NO. | DESCRIPTION           |
| 1                  | Head/Casing Assembly | 10  | Operator Rod            | 13a | Retaining Ring        |
| 1a                 | Head                 | 11  | Face Nut Washer         | 13b | Valve Body            |
| 1b                 | Casing               | 12  | Vacuum Breaker Assembly | 13c | Valve Actuator        |
| 1c                 | Valve Housing        | 12a | VB Cap                  | 13d | Nylon Thrust Washer   |
| 3                  | Key                  | 12b | VB Body                 | 13e | Rotating Ceramic Disc |
| 7                  | Face Nut             | 12c | VB Washer               | 13f | Fixed Ceramic Disc    |
| 8                  | Actuator Shaft       | 12d | VB "O" Ring             | 13g | Silicon Rubber Seal   |
| 9                  | Actuator "O" Ring    | 12e | VB Piston               | 13h | Retainer Guide (2)    |
|                    |                      | 13  | Valve Body Assembly     | 14  | Backer Plate w/Screws |

|             |   |  |                          |                         |                  |                      |                                    |
|-------------|---|--|--------------------------|-------------------------|------------------|----------------------|------------------------------------|
| H<br>T<br>E | 9-22-94<br>9-21-93<br>5-21-92<br>10-25-91 | Added HPRK-7VB Note<br>Chg'd note<br>Change Replacement Pts.<br>Update Figure Number | EMB<br>EMB<br>TWK<br>TWK | CL<br>JCS<br>JCS<br>JCS | WEIGHT<br>POUNDS | VOLUME<br>CUBIC FEET | FIGURE NUMBER<br><b>5609QT-CAN</b> |
| REV.        | DATE                                      | DESCRIPTION  | BY                       | CKD. BY                 |                  |                      |                                    |