



JAY R. SMITH CO.

PLUMBING & DRAINAGE PRODUCTS

959 Alness Street, North York, Ontario M3J 2J1
 TEL: (416) 736-9610 FAX: (416) 736-3789

LOCATION

LAVATORY SUPPORTS WITH CONCEALED ARMS

WALL MOUNTED

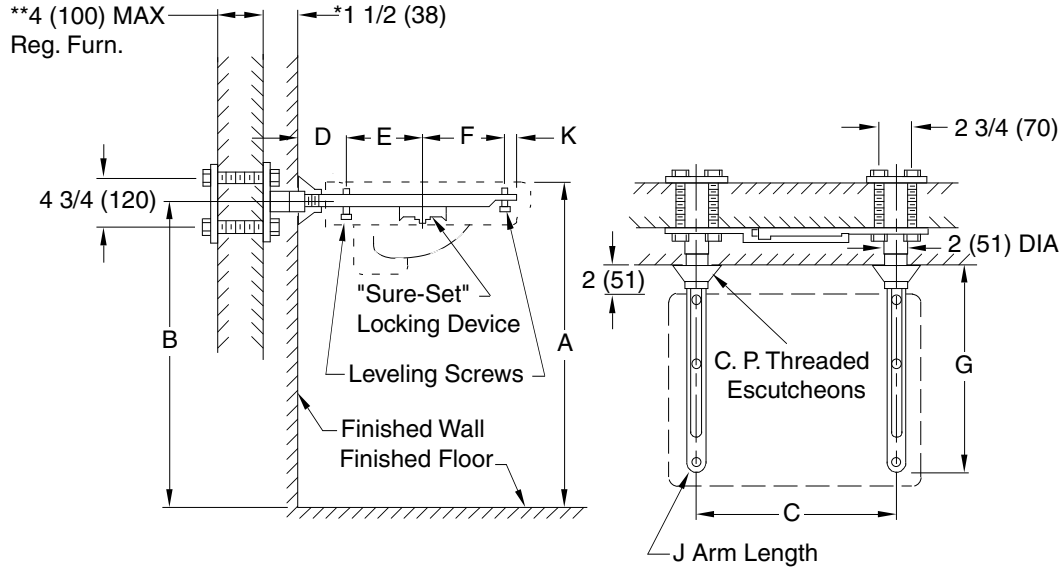

Fig. 0720 (-E) ... FOR FLAT SLAB LAVATORIES SET ON MASONRY OR STUD WALL

* This dimension can be increased when required (specify thickness).

** For greater wall thickness, longer supporting studs can be furnished (specify wall thickness).

ROUGHING-IN TABLE

FIXTURE NAME		NUMBER		SIZE					
A	B	C	D	E	F	G	J	K	

NOTE: The rough-in dimensions listed on this drawing are based on current information available to Jay R. Smith by the fixture manufacturers. We recommend that you verify these dimensions with the fixture manufacturer. We will not accept responsibility for rough-in dimension changes by the fixture manufacturer.

NOTE: Dimensions shown in parenthesis are in millimeters.

FIGURE NUMBER **0720 (-E)-CAN**

DRAWN BY: SL

CHECKED BY: RP

APPROVED BY:

DATE: 9-11-63

SCALE: NONE

SIZE: A

DRAWING NUMBER: S0720 (-E) (B)-CAN

B

DIMENSIONS ARE SUBJECT TO MANUFACTURERS TOLERANCE AND CHANGE WITHOUT NOTICE
 WE CAN ASSUME NO RESPONSIBILITY FOR USE OF SUPERSEDED OR VOID DATA

	B	4-10-95	Chg'd Dim, Added Millimeters	EMB		WEIGHT	VOLUME	FIGURE NUMBER
	A	8-9-93	Submittal Update	EMB	BS	POUNDS	CUBIC FEET	0720 (-E)-CAN
REV.	DATE	DESCRIPTION			BY	CKD. BY		