

B



JAY R. SMITH MFG. CO.®
 DIVISION OF SMITH INDUSTRIES, INC.
 POST OFFICE BOX 3237
 MONTGOMERY, ALABAMA 36109-0237 (USA)
 TEL: 334-277-8520 FAX: 334-272-7396 www.jrsmith.com



MEMBER OF:

LOCATION

DRAIN TILE SUMP

DRAIN TILE SUMP WITH 4" (100) TILE INLETS

FUNCTION: Provides a sump with multiple inlets into which the foundation drain tile lines are connected.

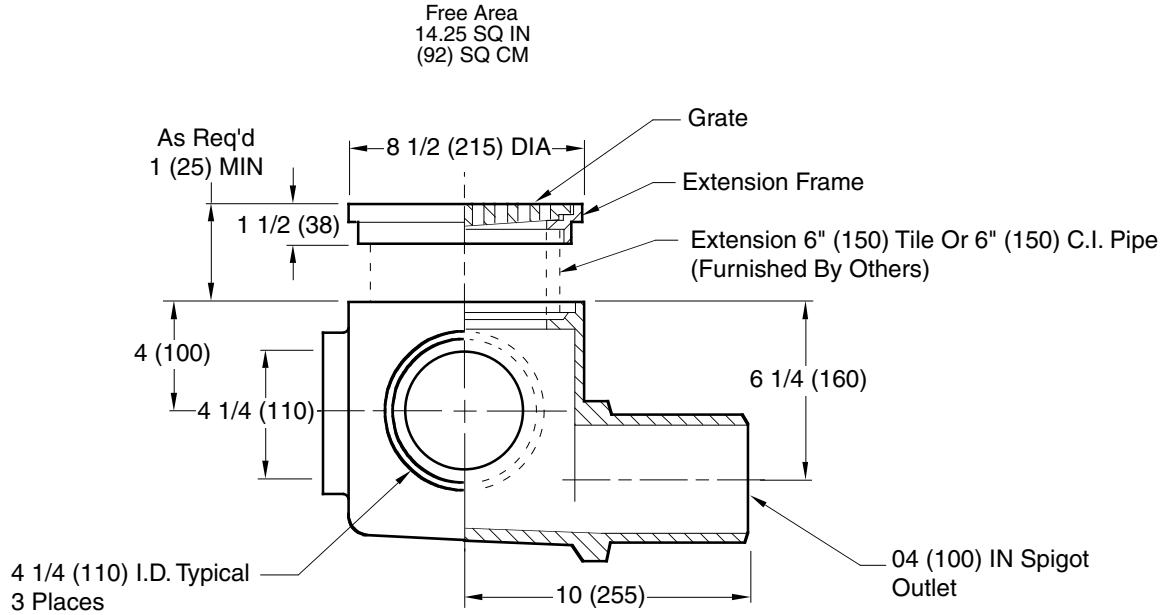

Fig 7097S04 . . . SPIGOT OUTLET

Sized for Service Weight and/or NO-HUB

NOTE: Dimensions shown in parentheses are in millimeters.

REGULARLY FURNISHED:
 Duco Cast Iron Body and Extension Frame with Cast Iron Slotted Grate.



VARIATIONS:
 Body Only (Fig. 7098)
 Solid Cast Iron Cover -SC



OPTIONAL MATERIALS:
 Galvanized Cast Iron -G
 Nickel Bronze Top -NB
 Polished Bronze Top -PB

DRAWING NUMBER
S7097

SIZE
A

SCALE:
NONE

DATE:
5-12-83

APPROVED BY:
SJM

CHECKED BY:
DT

DRAWN BY:
BS

7097

WE CAN ASSUME NO RESPONSIBILITY FOR USE OF SUPERSEDED OR VOID DATA
DIMENSIONS ARE SUBJECT TO MANUFACTURERS TOLERANCE AND CHANGE WITHOUT NOTICE

| | | | | |
|--------|--------------------|---------------------------------------|------------|----------|
| B A | 4-17-97 8-19-94 | Added Millimeters Submittal Update | EMB EMB | BS BS |
| REV. | DATE | DESCRIPTION | BY | CKD. BY |

WEIGHT
POUNDS

VOLUME
CUBIC FEET

FIGURE NUMBER

7097