

SENTINEL ALARM SYSTEM

ADVANCED WARNING OF DRAINAGE SYSTEM Backup

Jay R. Smith Mfg. Co.®

a better way

The Sentinel Alarm System is designed to be a better way of notifying the building maintenance staff or homeowner there is a backup condition detected in the sewer line and not to use plumbing fixtures due to an impending flood condition.

BENEFITS OF THE SENTINEL, FIG. 7141 ALARM SYSTEM

- Advance warning of pending sewer backup or flood condition.
- Can be installed in an existing drainage system.
- Works with a backwater valve or on its own.
- Works with a standard 120 VAC plug.

HOW IT WORKS:

The Sentinel Alarm System is activated by a pressure increase in the vertical portion of the sewer cleanout tee due to a backup condition. When this condition occurs a pressure switch in the alarm box closes sounding the audible alarm and activating the red light. The red light remains on for as long as the sewer has back pressure, warning that plumbing fixtures should not be used.

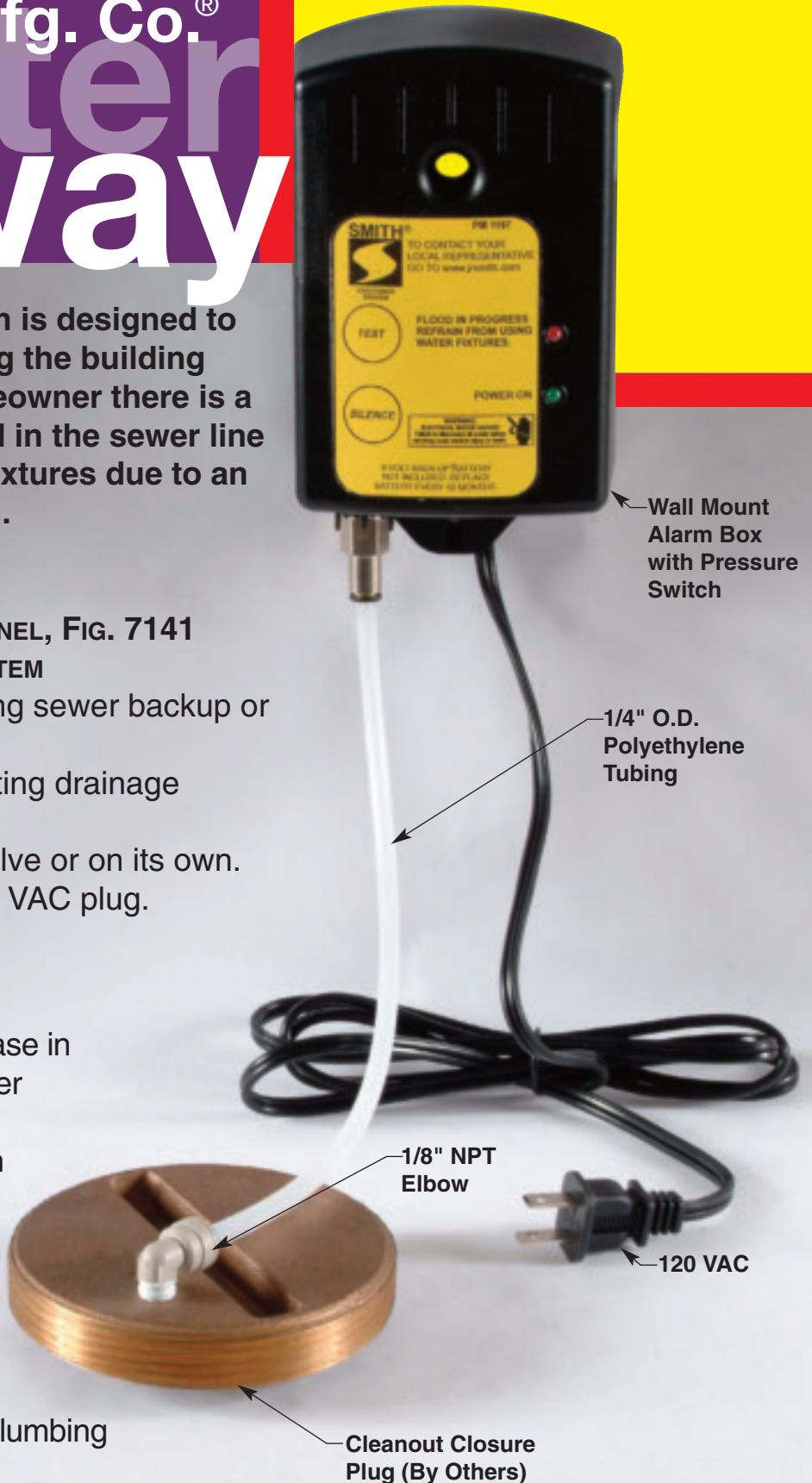

SENTINEL ALARM SYSTEM

Alarm Activation: When the sewer backs up to a level of 5 to 6 inches above the horizontal drain line, the pressure switch closes the 9V circuit sounding the alarm and turning on a red light. The alarm will continue to sound until the silence button is pressed. The red light will remain on for as long as the sewer has back pressure warning that the fixtures should not be used. When the red light goes off, the main sewer has returned to normal and use of the plumbing fixtures may resume. The switch resets automatically to be ready to detect the next backup condition.

KEY FEATURES:

- Residential and commercial application
- Optional add-on to the Flood-Gate® Automatic Backwater Valve, Fig. 7140. Eliminates the need for any wiring into the Flood-Gate® pit
- Can be used as a stand alone application regardless of backwater valve type used
- Possible integration into monitoring devices and central security unit
- CSA certified
- UL listed components

REGULARLY FURNISHED:

- Wall Mount Alarm Box with Pressure Switch
- 15 Feet of 1/4 O.D. Polyethylene Tubing
- 1/8 NPT Elbow
- Operates on 120 VAC or 9 Volt battery (not included)

NOTE: For proper operation, all connections between the tubing, fittings and cleanout plug MUST be airtight.

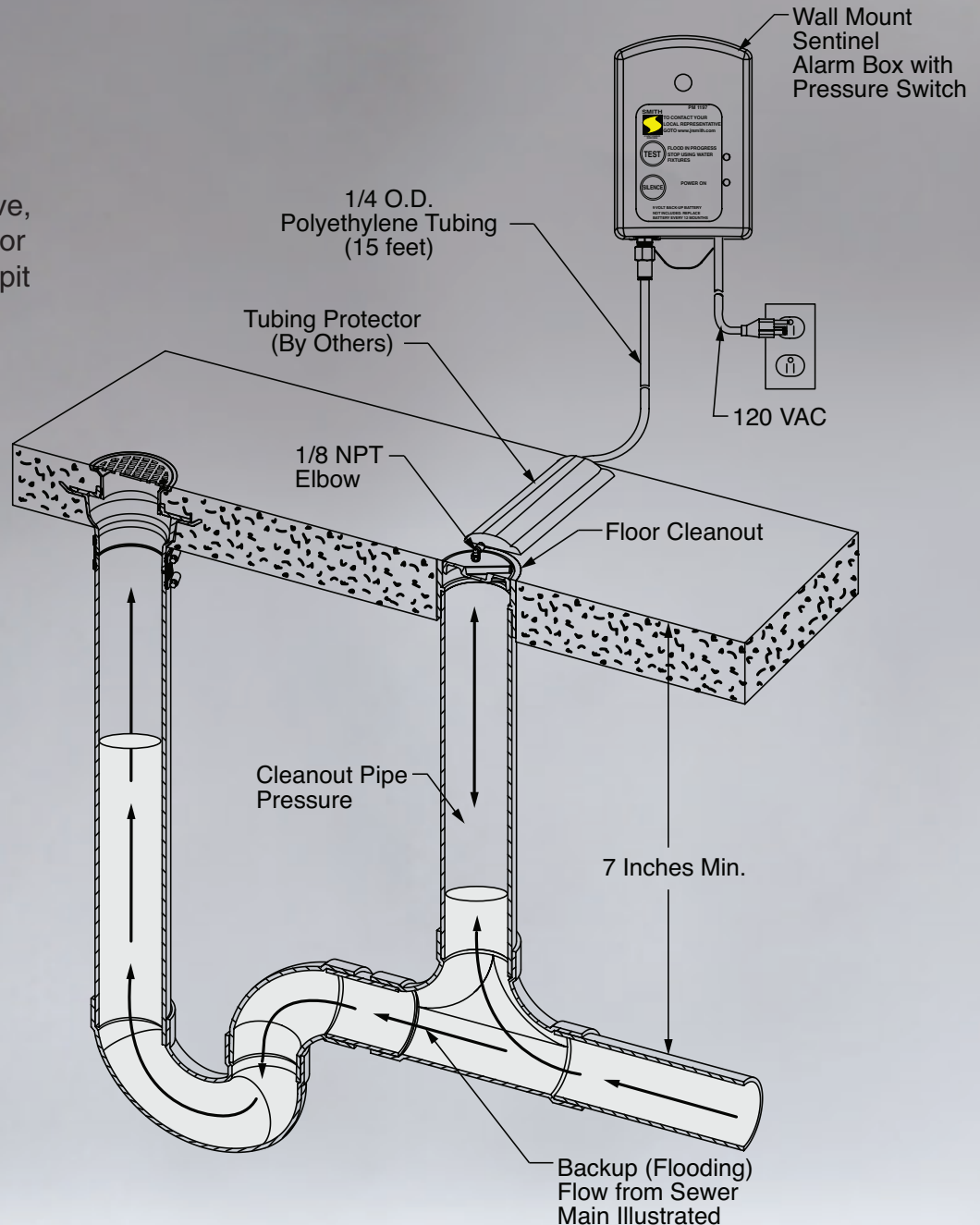

For more information on the Sentinel Alarm, Flood Gate® Automatic Backwater Valve or to contact your local Representative, visit www.jrsmith.com



JAY R. SMITH MFG. CO.®
 DIVISION OF SMITH INDUSTRIES, INC.
 POST OFFICE BOX 3237
 MONTGOMERY, ALABAMA 36109-0237 (USA)
 TEL: 334-277-8520 FAX: 334-272-7396 www.jrsmith.com



MEMBER OF: