



**Fig. # 1005 and 1605**  
Siphonic Roof Drains

**Product Features:**

- The air baffle on the roof drain promotes full-bore flow.
- Full-bore flow within the piping reduces pipe diameter as compared to open channel, traditional gravity flow, which operates at 1/2 the capacity.
- Siphonic action is independent of pipe pitch or gradient. Horizontal piping is not pitched. The invert leaving the building is eliminated.
- Smaller pipe diameters allows maximum use of open space without intrusion of drainage piping. This also reduces material costs.
- The point of discharge for the roof can be concentrated to one corner, typically, rather than out of the building in several points.
- Slab installation costs are minimized, reducing excavation, backfill costs, and exterior underground piping.
- Siphonic systems promote self cleaning of debris from the piping system.
- Fully tested and certified in accordance with ANSI/ASTM A112.6.9 "Siphonic Roof Drains."



The horizontal manifolds in a siphonic roof drain system installation.

# SIPHONIC ROOF DRAIN

## 15 1/4"(390) DIAMETER - LOW PROFILE DOME

**FUNCTION:** For use in engineered siphonic roof drainage system. May be used in flat roof of any construction. Large low profile dome provides sufficient free area for quick drainage of rainwater and protects the drain sump, baffle and connected piping from the intrusion of debris. Internal air baffle creates siphonic drainage action producing more efficient drainage than traditional roof drains.

**Performance Data		
A(Pipe Size) in. (mm)	Max. Capacity cfs (lps)	Resistance Value, K
02 (50)	0.50 (41.2)	0.13
0250 (64)	0.60 (17.0)	0.13
03 (75)	1.40 (39.5)	0.16
04 (100)	1.70 (48.1)	0.23

\*\*As tested and certified by ANSI/ASME A112.6.9 "Siphonic Roof Drains" Procedures and test apparatus. IAPMO Listed File No. 5138

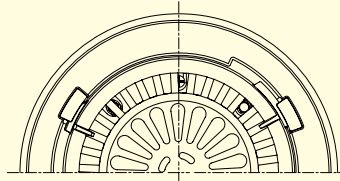

**Free Area**  
102.5 Sq. In.  
(661) Sq. Cm.

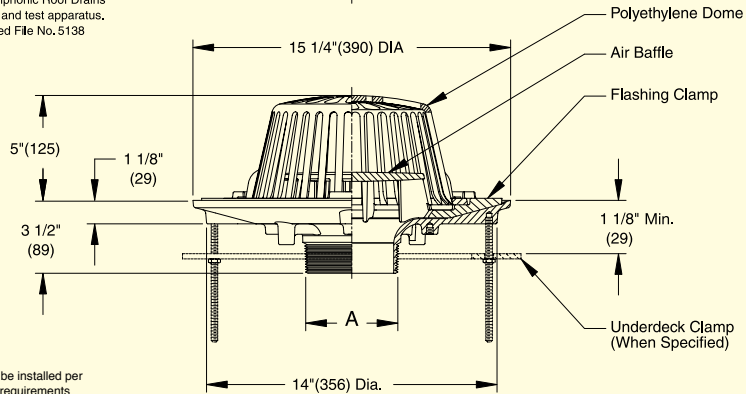

**NOTES:**

1. Drain shall be installed per local code requirements
2. 2 1/2" pipe size only available with male threaded outlet.
3. Dimensions shown in parentheses are in millimeters.

A(Pipe Size) = 02(50), \*0250(64), 03(75) or 04(100)

- Fig. 1005T ..... MALE THREADED OUTLET
- Fig. 1005Y ..... \*NO HUB OUTLET

recommended deck opening

with suffix -R	17 (430) DIA
less suffix -R	14 (355) DIA

**REGULARLY FURNISHED:**

Duco Cast Iron Body, Flashing Clamp, Air Baffle and Polyethylene Dome.

**VARIATIONS:**

- Sump Receiver -R
- Underdeck Clamp -C
- Underdeck Clamp for 10" Deck Opening -C10
- "L" Shaped Underdeck Clamp -CL
- Vandal Proof Dome -U

**OPTIONAL MATERIALS:**

- Aluminum Dome -AD
- Cast Iron Dome -CID
- Galvanized Cast Iron Dome -CIDG
- Galvanized Cast Iron -G
- Rough Bronze Dome -RBD

# SIPHONIC GUTTER DRAIN

## 6"(150) DIAMETER - LOW PROFILE GUTTER DRAIN

**FUNCTION:** For use in engineered siphonic roof drainage systems for gutters, parapets, small balconies, sills, cornices, marquees and other small overhanging areas where drainage of rainwater is required. Air baffle creates siphonic drainage action producing a more efficient drainage than traditional gutter drains.

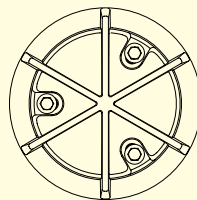

**Free Area**  
5.42 Sq. In.  
(35) Sq. Cm.

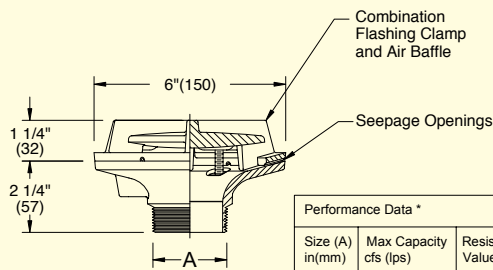

A(Pipe Size) = 02(50)

- Vandal Proof -U

Performance Data *		
Size (A) in(mm)	Max Capacity cfs (lps)	Resistance Value, K
02 (50)	0.40 (11.3)	0.66

- Galvanized Cast Iron -G

\*As tested and certified by ANSI/ASME A112.6.9 "Siphonic Roof Drains" procedures and test apparatus.

**Regularly Furnished:** Duco Cast Iron Body with Combination Flashing Clamp and Air Baffle.

# SIPHONIC ROOF DRAIN

## 15 1/4"(390) DIAMETER - LOW PROFILE DOME

**FUNCTION:** For use in engineered siphonic roof drainage system. May be used in flat roof of any construction. Large low profile dome provides sufficient free area for quick drainage of rain water and protects the drain sump, baffle and connected piping from the intrusion of debris. Internal air baffle creates siphonic drainage action producing more efficient drainage than traditional roof drains.

**Free Area**  
 102.5 Sq. In.  
 (661) Sq. Cm.

**\*\*Performance Data**

A(Pipe Size) in. (mm)	Max. Capacity cfs (lps)	Resistance Value, K
02 (50)	0.50 (41.2)	0.13
0250 (64)	0.60 (17.0)	0.13
03 (75)	1.40 (39.5)	0.16
04 (100)	1.70 (48.1)	0.23

\*\*As tested and certified by ANSI/ASME  
 A112.6.9 "Siphonic Roof Drains"  
 Procedures and test apparatus.  
 IAPMO Listed File No. 5138

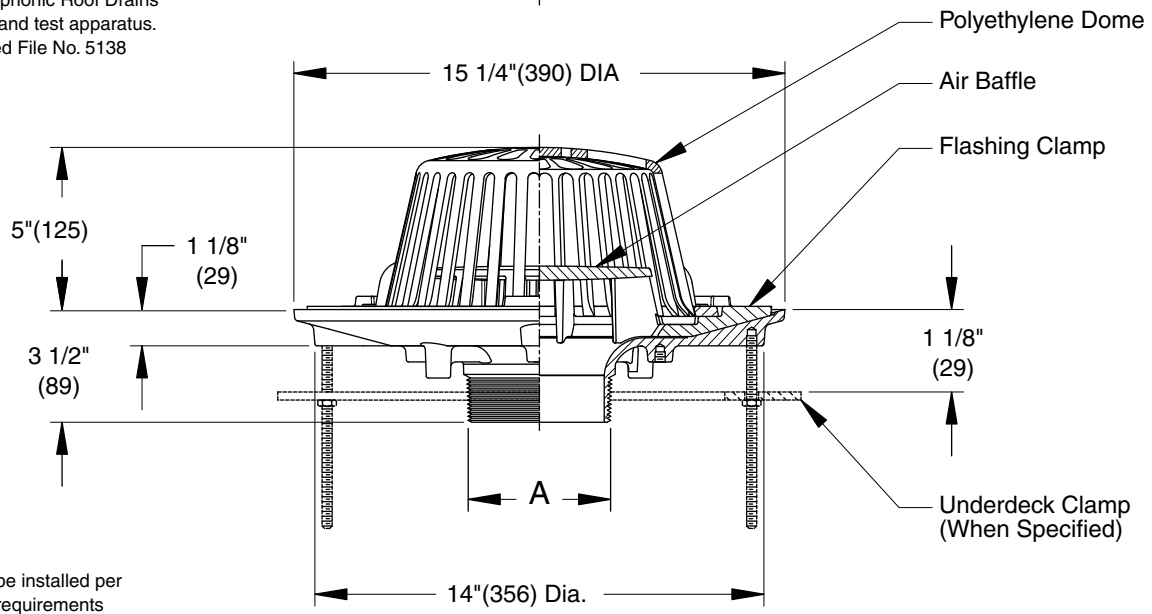
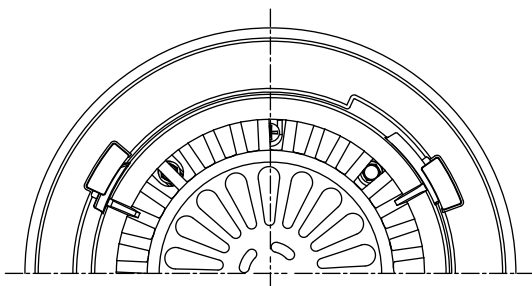

**NOTES:**

1. Drain shall be installed per local code requirements
- \*2 1/2" pipe size only available with male threaded outlet.
3. Dimensions shown in parentheses are in millimeters.

A(Pipe Size) = 02(50), \*0250(64), 03(75) or 04(100)

- Fig. 1005T ..... MALE THREADED OUTLET
- Fig. 1005Y ..... \*NO HUB OUTLET

recommended deck opening

with suffix -R	17 (430) DIA
less suffix -R	14 (355) DIA

**REGULARLY FURNISHED:**

Duco Cast Iron Body, Flashing Clamp, Air Baffle and Polyethylene Dome.

**VARIATIONS:**

- Sump Receiver -R
- Underdeck Clamp -C
- Underdeck Clamp for 10" Deck Opening -C10
- "L" Shaped Underdeck Clamp -CL
- Vandal Proof Dome -U

**OPTIONAL MATERIALS:**

- Aluminum Dome -AD
- Cast Iron Dome -CID
- Galvanized Cast Iron Dome -CIDG
- Galvanized Cast Iron -G
- Rough Bronze Dome -RBD

DRAWING NUMBER S1005  
 SIZE A  
 SCALE: NONE  
 DATE: 4-14-06  
 APPROVED BY: CR  
 CHECKED BY: CR  
 DRAWN BY: RN  
 1005  
 DIMENSIONS ARE SUBJECT TO MANUFACTURERS TOLERANCE AND CHANGE WITHOUT NOTICE  
 WE CAN ASSUME NO RESPONSIBILITY FOR USE OF SUPERSEDED OR VOID DATA

<b>B</b>	5-21-07	Added Notes	<b>RN</b>	<b>CL</b>	WEIGHT POUNDS	VOLUME CUBIC FEET	<b>FIGURE NUMBER</b> <b>1005</b>
<b>A</b>	5-10-06	Added Notes	<b>TBW</b>	<b>CL</b>			
REV.	DATE	DESCRIPTION	BY	CKD. BY			

C  
 DRAWING NUMBER S1605  
 SIZE A  
 SCALE: NONE  
 DATE: 4-14-06  
 APPROVED BY: CR  
 CHECKED BY: CR  
 DRAWN BY: RN  
 FIGURE NUMBER 1605

WE CAN ASSUME NO RESPONSIBILITY FOR USE OF SUPERSEDED OR VOID DATA

# SIPHONIC GUTTER DRAIN

## 6"(150) DIAMETER - LOW PROFILE GUTTER DRAIN

**FUNCTION:** For use in engineered siphonic roof drainage systems for gutters, parapets, small balconies, sills, cornices, marquees and other small overhanging areas where drainage of rainwater is required. Air baffle creates siphonic drainage action producing more efficient drainage than traditional gutter drains.

**Free Area**  
 5.42 Sq. In.  
 (35) Sq. Cm.

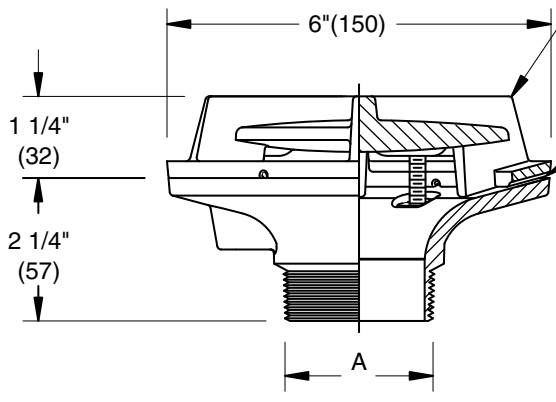
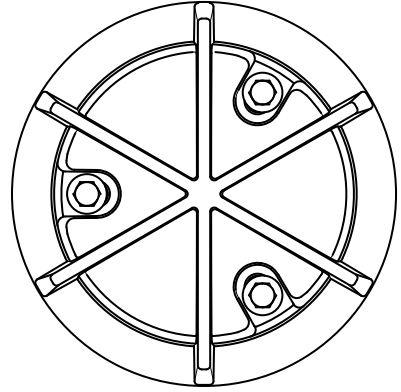

Combination Flashing  
 Clamp and Air Baffle

Seepage Openings

- NOTES:**
1. Drain shall be installed per local code requirements
  2. Dimensions shown in parentheses are in millimeters.

Performance Data *		
Size (A) in(mm)	Max Capacity cfs (lps)	Resistance Value, K
02 (50)	0.40 (11.3)	0.66

- Fig. 1605T ..... MALE THREADED OUTLET  
 Fig. 1605Y ..... NO HUB OUTLET

**REGULARLY FURNISHED:**  
 Duco Cast Iron Body with  
 Combination Flashing Clamp and  
 Air Baffle.

**VARIATIONS:**  
 Vandal Proof -U

**OPTIONAL MATERIALS:**  
 Galvanized Cast Iron -G

\*As tested and certified by ANSI/ASME A112.6.9 "Siphonic Roof Drains" procedures and test apparatus.  
 IAPMO Listed File No. 5138

U.S. Patent No. D576,257S

REV.	DATE	DESCRIPTION	BY	CKD. BY
C	10-10-08	Added Patent No.	RN	CL
B	5-21-07	Added Notes	RN	CL
A	5-10-06	Added Notes	TBW	CL

WEIGHT POUNDS	VOLUME CUBIC FEET	<b>FIGURE NUMBER</b>  <b>1605</b>
------------------	----------------------	---