

# TOP MOUNT DRAIN ELEVATOR

**FUNCTION:** Used to elevate the Figure 1010 type roof drains on top side of roof deck to compensate for insulation thickness.



**Fig. # 1010DEK**  
Top Mount Drain Elevator

**Product Features:**

- Elevates Figure # 1010 type roof drains
- Adjustable to compensate for insulation thickness

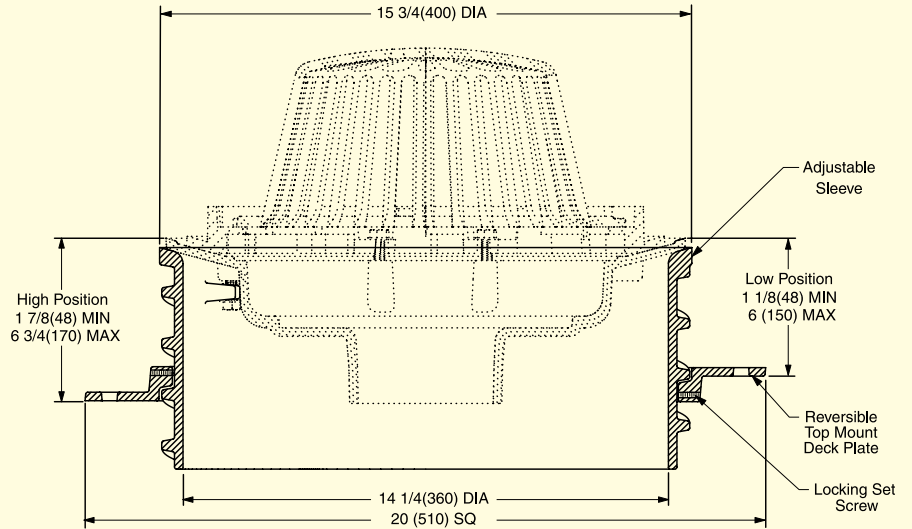

**NOTE:** 16 1/2(420) diameter deck opening recommended.

**REGULARLY FURNISHED:**  
Duco Coated Cast Iron Adjustable Sleeve and Top Mount Reversible Deck Plate.

**OPTIONAL MATERIALS:**  
 Galvanized Cast Iron -G

**NOTE:** Dimensions shown in parentheses are in millimeters.



**JAY R. SMITH MFG. CO.**  
 DIVISION OF SMITH INDUSTRIES, INC.  
 POST OFFICE BOX 3237  
 MONTGOMERY, ALABAMA 36109-0237 (USA)  
 TEL: 334-277-8520 FAX: 334-272-7396 www.jrsmith.com



LOCATION

# TOP MOUNT DRAIN ELEVATOR

**FUNCTION:** Used to elevate the figure 1010 type roof drains on top side of roof deck to compensate for insulation thickness.

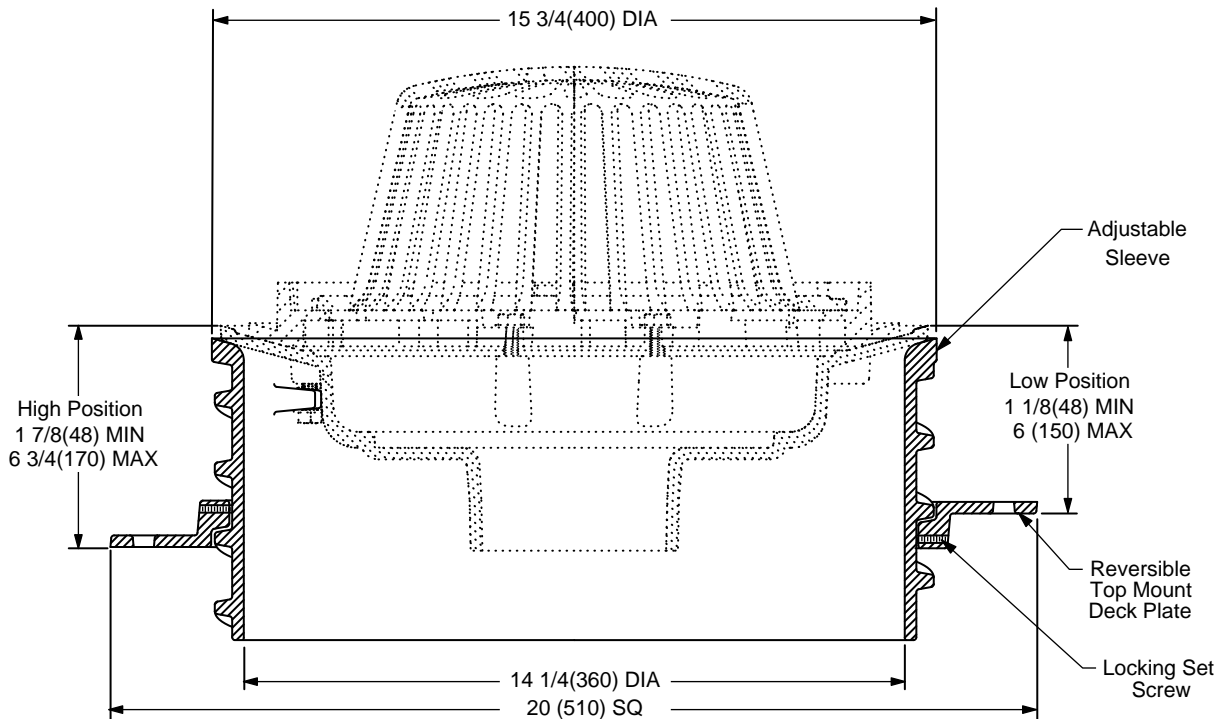

**NOTE:** 16 1/2 (420) diameter deck opening recommended.

**REGULARLY FURNISHED:**  
 Duco Coated Cast Iron Adjustable Sleeve and Top Mount Reversible Deck Plate.

**OPTIONAL MATERIALS:**  
 Galvanized Cast Iron -G

**NOTE:** Dimensions shown in parentheses are in millimeters.

DRAWING NUMBER  
s1010DEK

SIZE  
A

SCALE:  
NONE

DATE:  
6-22-06

APPROVED BY:  
CEL

CHECKED BY:  
CL

DRAWN BY:  
RN

FIGURE NUMBER  
1010DEK

DIMENSIONS ARE SUBJECT TO MANUFACTURERS TOLERANCE AND CHANGE WITHOUT NOTICE WE CAN ASSUME NO RESPONSIBILITY FOR USE OF SUPERSEDED OR VOID DATA

REV.	DATE	DESCRIPTION	BY	CKD.

WEIGHT POUNDS	VOLUME CUBIC FEET

<b>FIGURE NUMBER</b>
<b>1010DEK</b>