

FIGURE NUMBER	<b>9870-491-HPP</b>	DRAWN BY:	RN	CHECKED BY:	PJ	APPROVED BY:	PJ	DATE:	9-24-04	SCALE:	NONE	SIZE	<b>A</b>	DRAWING NUMBER	a9870-491-HPP	C
---------------	---------------------	-----------	----	-------------	----	--------------	----	-------	---------	--------	------	------	----------	----------------	---------------	---

DIMENSIONS ARE SUBJECT TO MANUFACTURERS TOLERANCE AND CHANGE WITHOUT NOTICE

WE CAN ASSUME NO RESPONSIBILITY FOR USE OF SUPERSEDED OR VOID DATA

# 9870-491-HPP GRATE SPECIFICATION SHEET

**Light Duty, DIN 19580 Class A - 3,500 lbs - 70 psi**  
**For pedestrian, wheel chair and bicycle traffic**

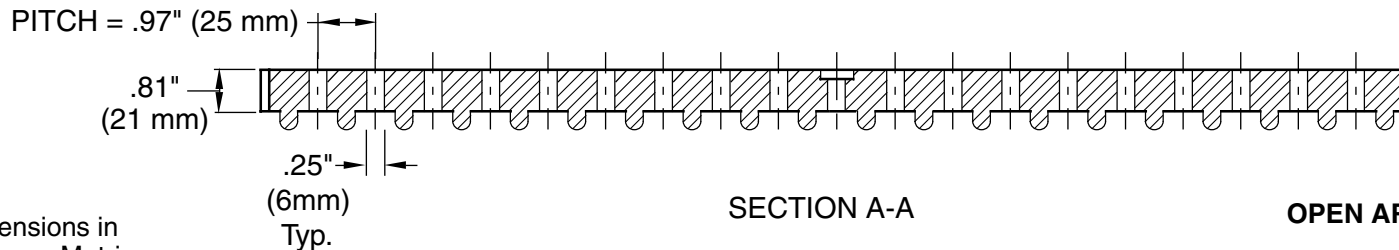
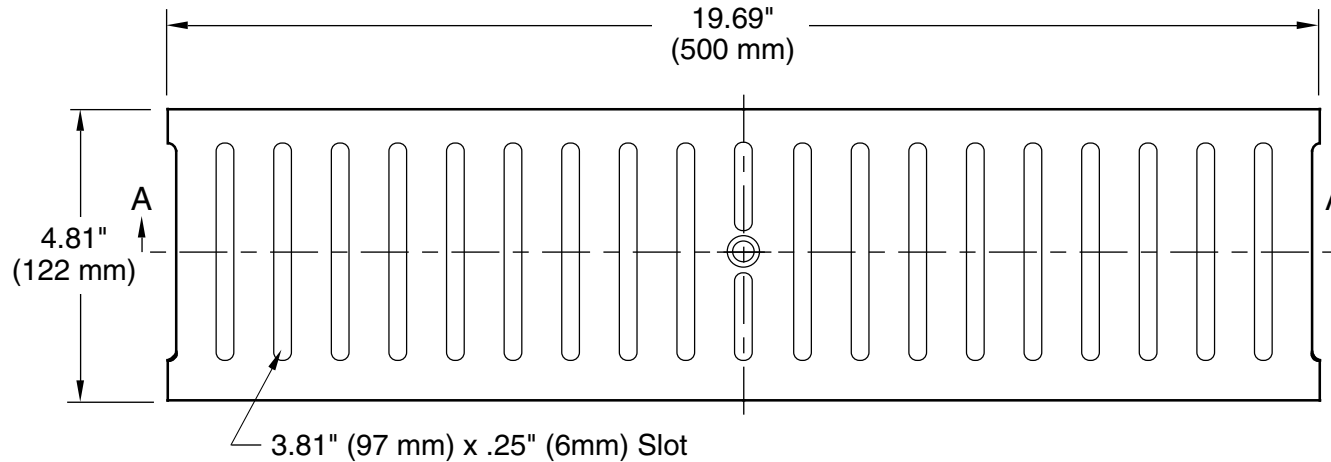

**NOTE:** Dimensions in parentheses are Metric.

**OPEN AREA: 17.55 SQ. IN.**

**REGULARLY FURNISHED:**  
 Black Molded Polypropylene 1/2 Meter  
 Long Heel Proof Grate w/Locking Device.

- VARIATIONS:**
- Beige Color
  - Light Grey Color
  - Dark Grey Color
  - White Color
  - Locking Device - 0814LD

- Beige Overlay Rails
- Light Grey Overlay Rails
- Dark Grey Overlay Rails
- White Overlay Rails



**SMITH® JAY R. SMITH MFG. CO.®**  
 DIVISION OF SMITH INDUSTRIES, INC.  
 POST OFFICE BOX 3237  
 MONTGOMERY, ALABAMA 36109-0237 (USA)  
 TEL: 334-277-8520 FAX: 334-272-7396 www.jrsmith.com



REV.	DATE	DESCRIPTION	BY	CKD. BY
C	5/02/08	Revised Locking Device	RN	PJ
B	11/15/07	Added White Color Variation and Overlay Rails	RN	MD
A	7/18/05	Added White Color Variation	RN	PJ