



**JAY R. SMITH MFG. CO.**  
 DIVISION OF SMITH INDUSTRIES, INC.  
 POST OFFICE BOX 3237  
 MONTGOMERY, ALABAMA 36109-0237 (USA)  
 TEL: 334-277-8520 FAX: 334-272-7396 www.jrsmith.com



MEMBER OF:

LOCATION

# BARIATRIC WALL MOUNTED TOILET

## GUIDE SPECIFICATION

Provide and install Jay R. Smith Fig. 9901 Bariatric Toilet (specify model number and options) rated at 1000 lbs. Fixture shall be fabricated from 16 gage, type 304 stainless steel. Construction shall be seamless welded and all surfaces shall have a satin finish with an integral contoured toilet seat. Toilet shall be concealed Siphon Jet type with an elongated bowl and a self-draining flushing rim. Toilet shall meet ASME A112.19.3-2008 and CSA B45.4-2008 requirements and will flush with a minimum of 25 PSI flow pressure when used in conjunction with a minimum of 1.6 gpf. Toilet trap shall have a minimum 3-1/2" seal that shall pass a 2-1/8" diameter ball and be fully enclosed. Toilet waste outlet shall be Gasketed Waste.



See Reverse Side for Options and Dimensions

Fig. 9901-W-CN Shown

## REGULARLY FURNISHED:

Toilet is fabricated from 16 gage, type 304 stainless steel, seamless welded construction with integral contoured seat. Toilet is a siphon jet type with an elongated bowl manufactured to ASME A112.19.3-2008 and CSA B45.4-2008 requirements and will flush with a minimum of 25 PSI flow pressure when used in conjunction with a minimum of 1.6 gpf flush valve. Toilet has a 1-1/2" (38) NPT flush valve connection and requires a minimum of 25 PSI flow pressure and uses a minimum water consumption of 1.6 gallons per flush. The trap has a minimum 3-1/2" (89) seal and will pass a 2-1/8" (54) diameter ball and is fully enclosed. Toilet waste outlet is gasketed.

**NOTE:** Dimensions shown in parentheses are in millimeters

DRAWING NUMBER  
9901

SIZE  
A

SCALE:  
NONE

DATE:  
10-12-10

APPROVED BY:  
CL

CHECKED BY:  
CL

DRAWN BY:  
TBW

FIGURE NUMBER  
9901

WE CAN ASSUME NO RESPONSIBILITY FOR USE OF SUPERSEDED OR VOID DATA

DIMENSIONS ARE SUBJECT TO MANUFACTURERS TOLERANCE AND CHANGE WITHOUT NOTICE

REV.	DATE	DESCRIPTION	BY	CKD. BY	WEIGHT POUNDS	VOLUME CUBIC FEET	FIGURE NUMBER <b>9901</b>
------	------	-------------	----	---------	---------------	-------------------	------------------------------



**JAY R. SMITH MFG. CO.**  
 DIVISION OF SMITH INDUSTRIES, INC.  
 POST OFFICE BOX 3237  
 MONTGOMERY, ALABAMA 36109-0237 (USA)  
 TEL: 334-277-8520 FAX: 334-272-7396 www.jrsmith.com



MEMBER OF:

LOCATION

# BARIATRIC WALL MOUNTED TOILET

## MODEL NUMBER AND OPTIONS SELECTION:

### BASE MODEL NUMBER

9901 Bariatric Toilet

### SUPPLY (Must Specify)

-T Top (Exposed)  
 -W Wall (Concealed)

### FLUSH VALVE GPF's (Must Specify)

-HET 1.28 GPF  
 -ULF 1.6 GPF  
 -3.5 GPF

### FLUSH VALVE OPTIONS (Must Specify)

-EVSFV Master-Trol Flush Valve  
 (N/A for Top Supply)  
 -FV Flush Valve (N/A for ADA)  
 -FVBO Flush Valve by Others  
 -FVC Cover, Flush Valve (N/A for ADA)  
 -FVCH Cover, Hydraulic Flush Valve  
 -FVH Flush Valve, Hydraulic  
 -FVL Flush Valve, Lever Handle  
 -MVCFV Time-Trol Flush Valve  
 (N/A for Top Supply)

### PRODUCT OPTIONS (Must Specify)

-ADA Integral Seat Height  
 -BCN Blind Cap Nuts (4)  
 -BL BedPan Nuts (4)  
 -CN Cap Nuts (4)  
 -EG Enviro-Glaze: Specify Color: \_\_\_\_\_  
 Toilet Exterior Only  
 Toilet Interior  
 14 Gage Housing  
 -FT Flood-Trol (N/A for Top Supply)  
 -FTA Flood-Trol Auto-Reset (N/A for Top Supply)  
 -FTE Flood-Trol Electronic  
 -FVT Flush Valve Thru Wall Connection  
 -HET High Efficiency Toilet design  
 -HPS High Polish Integral Seat  
 -HSBJ Big John® Hinged Seat  
 Open Front Less Cover  
 Open Front With Cover  
 -MC Bariatric Mounting Carrier, 1000 lb Rating  
 Specify Type: \_\_\_\_\_  
 -PFS Punched for Seat by Others  
 -PH Paper Holder (Available Only with -FVC)  
 -TF Transformer, 120VAC to 24VAC  
 -TSC Toilet Shipping Cover  
 -VAC AcornVac System  
 -WO3 3" O.D. Toilet Waste Outlet (3.5 GPF Only)

DRAWING NUMBER  
9901BS

SIZE  
A

SCALE:  
NONE

DATE:  
10-12-10

APPROVED BY:  
CL

CHECKED BY:  
CL

DRAWN BY:  
TBW

9901BS

FIGURE NUMBER

WE CAN ASSUME NO RESPONSIBILITY FOR USE OF SUPERSEDED OR VOID DATA

DIMENSIONS ARE SUBJECT TO MANUFACTURERS TOLERANCE AND CHANGE WITHOUT NOTICE

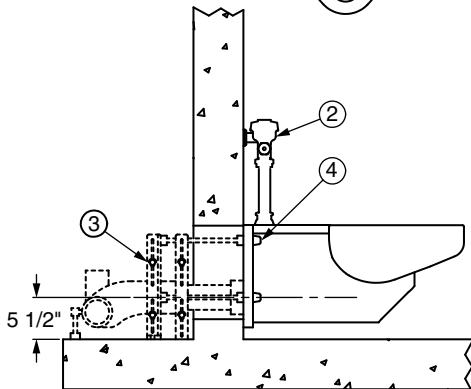
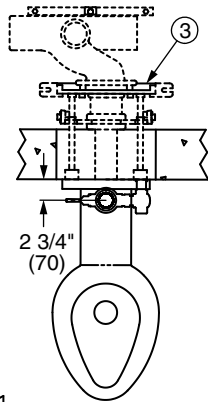

Fig. 9901-T

### NOTES:

- Optional -FV Flush Valve - Wall Supply.
- Optional -FV Flush Valve - Top Supply.
- Optional -MC Bariatric Mounting Carrier Shown.
- Optional -CN Cap nuts.

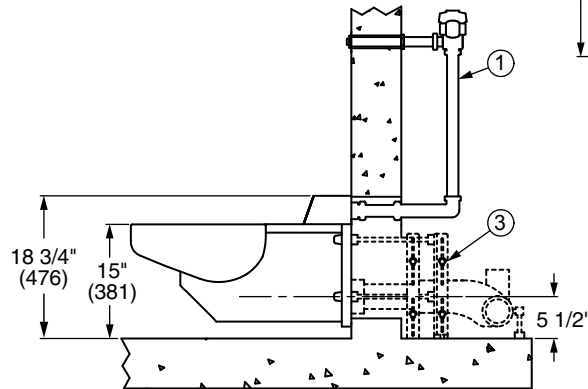
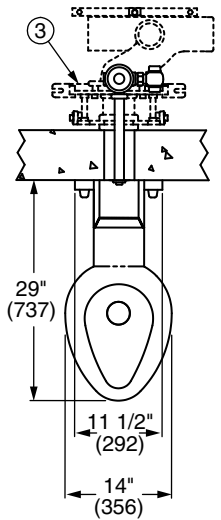

Fig. 9901-W



NOTE: Dimensions shown in parentheses are in millimeters

REV.	DATE	DESCRIPTION	BY	CKD. BY

WEIGHT POUNDS	VOLUME CUBIC FEET

FIGURE NUMBER  
**9901BS**