



LOCATION

SCUPPER DRAINS STAINLESS STEEL - CARBON STEEL

SCUPPER DRAIN WITH ANGLE GRATE

FUNCTION: Used at junction of roof and parapet. The angle grate prevents debris from blocking drainage.

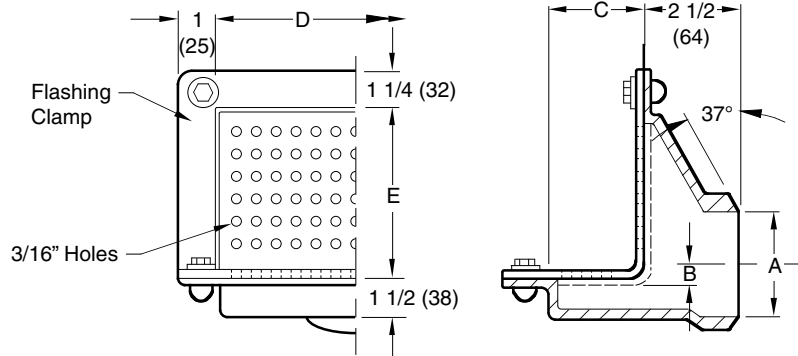

Fig. 9785FGSSBW... BUTT WELD OUTLET

PIPE SIZE	A	B	C	D	E	Free Area
02 (50)		1/4 (6)				
03 (75)		1/4 (6)	3 1/4 (83)	8 3/4 (220)	5 (125)	17.87 (115 SQ. CM)
04 (100)		1/2 (13)				
05 (125)		1 3/4 (44)				35
06 (150)		1 3/4 (44)	4 (100)	10 1/2 (265)	6 1/2 (165)	226 SQ. CM)

Schedule 40 Regularly Furnished

REGULARLY FURNISHED:
 CF8 (Equivalent to Type 304) Rough Finish Stainless Steel Body with Stainless Steel Vandal Proof Grate.

VARIATIONS:
 BW Butt Weld Outlet (Specify Schedule -S05, -S10 or -S40)

OPTIONAL MATERIALS:
 A-27 Carbon Steel Body -A27B
 All A-27 Carbon Steel -A27
 All CF8M (Equivalent to Type 316) Stainless Steel -316
 All CF8 Stainless Steel -304
 CF8M (Equivalent to Type 316) Stainless Steel Body -316

NOTE: Dimensions shown in parentheses are in millimeters.

DRAWING NUMBER
 S9785FGSS

SIZE
 A

SCALE:
 NONE

DATE:
 03/04/08

APPROVED BY:
 TK

CHECKED BY:
 TK

DRAWN BY:
 JJ

FIGURE NUMBER
 9785FGSS

WE CAN ASSUME NO RESPONSIBILITY FOR USE OF SUPERSEDED OR VOID DATA

DIMENSIONS ARE SUBJECT TO MANUFACTURERS TOLERANCE AND CHANGE WITHOUT NOTICE

REV.	DATE	DESCRIPTION	BY	CKD. BY

WEIGHT POUNDS	VOLUME CUBIC FEET

FIGURE NUMBER
9785FGSS