

## HEAVY DUTY FIXTURE SUPPORT FLOOR MOUNTED

**WITH SUPPORTING STUDS, ADJUSTABLE COUPLING AND WASTE FITTING**

DRAWING NUMBER: S0915 (B)  
 SIZE: A  
 SCALE: NONE  
 DATE: 2-9-70  
 APPROVED BY:  
 CHECKED BY:  
 DRAWN BY: 0915  
 DIMENSIONS ARE SUBJECT TO MANUFACTURERS TOLERANCE AND CHANGE WITHOUT NOTICE  
 WE CAN ASSUME NO RESPONSIBILITY FOR USE OF SUPERSEDED OR VOID DATA

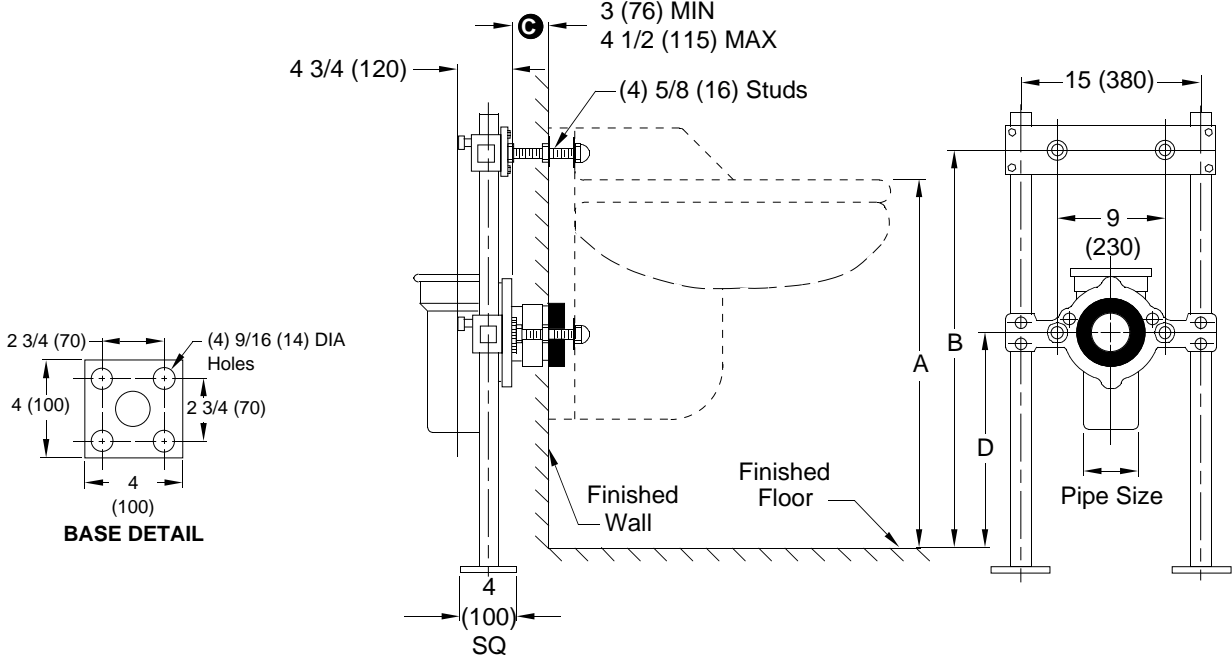

**Fig. 0915 . . . WITH SUPPORTING STUDS, ADJUSTABLE COUPLING AND WASTE FITTING 4" (100) CAULK AND 4" (100) VENT FOR BACK OUTLET FLUSHING RIM SERVICE SINK**

The water closet gasket regularly furnished is made of molded neoprene and designed to fit water closet outlet dimensions and configurations shown in ANSI Standard A112.19.2M-1982, Figure 13B. If gasket is not found to be compatible to fixture due to nonconformance of said fixture to ANSI A112.19.2M, then fixture manufacturer shall be consulted for a suitable gasket recommendation. Jay R. Smith assumes no liability for connections to fixtures which do not conform to these standards.

**ROUGHING-IN TABLE**

FIXTURE MFG.	NAME	NUMBER	SIZE	A	B	D

NOTE: The rough-in dimensions listed on this drawing are based on current information available to Jay R. Smith by the fixture manufacturers. We recommend that you verify these dimensions with the fixture manufacturer. We will not accept responsibility for rough-in dimension changes by the fixture manufacturer.

\*SPECIFY SIZE AND TYPE OF FITTING

NOTE: Dimensions shown in parenthesis are in millimeters.

For Extra Heavy Duty Support With 1 1/2" (38) Pipe Uprights, Add Suffix "X" to Figure Number.

Ⓢ This Dimension Can be Increased When Fixture Support is to be Installed Behind the Wall (Specify When Required and Wall Thickness.)

REV.	DATE	DESCRIPTION	BY	CKD. BY	WEIGHT POUNDS	VOLUME CUBIC FEET	<b>FIGURE NUMBER</b> <b>0915</b>