

C

SMITH® JAY R. SMITH MFG. CO.®
 DIVISION OF SMITH INDUSTRIES, INC.
 POST OFFICE BOX 3237
 MONTGOMERY, ALABAMA 36109-0237 (USA)
 TEL: 334-277-8520 FAX: 334-272-7396 www.jrsmith.com



LOCATION

LABOR SAVER™ LAVATORY SUPPORTS

FLOOR MOUNTED TYPE WITH EXPOSED ARMS

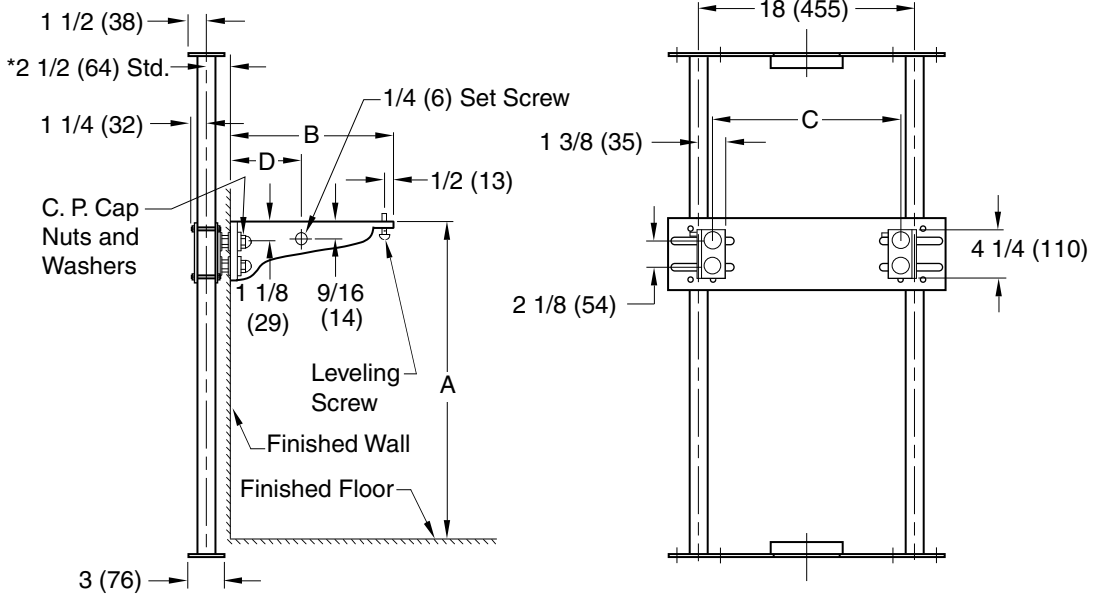
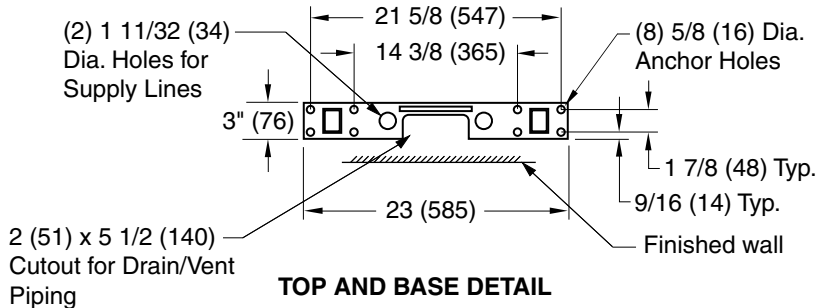

Fig. 0762 ... WITH OFFSET ARMS FOR HIGH BACK ENAMELED IRON LAVATORIES



NOTE: The rough-in dimensions listed on this drawing are based on current information available to Jay R. Smith by the fixture manufacturers. We recommend that you verify these dimensions with the fixture manufacturer. We will not accept responsibility for rough-in dimension changes by the fixture manufacturer.

NOTE: *This dimension can be increased when required (Specify wall thickness).

NOTE: Dimensions shown in parenthesis are in millimeters.

ROUGH-IN TABLE

FIXTURE MFG.	NAME	NUMBER	SIZE	A	B	C	D

DRAWING NUMBER
S0762

SIZE
A

SCALE:
NONE

DATE:
04/09/01

APPROVED BY:
AM

CHECKED BY:
CR

DRAWN BY:
JJ

0762

FIGURE NUMBER

WE CAN ASSUME NO RESPONSIBILITY FOR USE OF SUPERSEDED OR VOID DATA

DIMENSIONS ARE SUBJECT TO MANUFACTURERS TOLERANCE AND CHANGE WITHOUT NOTICE

REV.	DATE	DESCRIPTION	BY	CKD. BY
C	11/08/02	Changed per George Flegel	JJ	AM
B	12/19/01	Changed Hole Size in Base	JJ	AM
A	11/06/01	Inside wall (washer/nut/washer)	JJ	AM

WEIGHT POUNDS	VOLUME CUBIC FEET	FIGURE NUMBER
		0762