

# LAVATORY SUPPORTS WITH EXPOSED ARMS

## FLOOR MOUNTED WITH "PRO-SET" UPRIGHTS

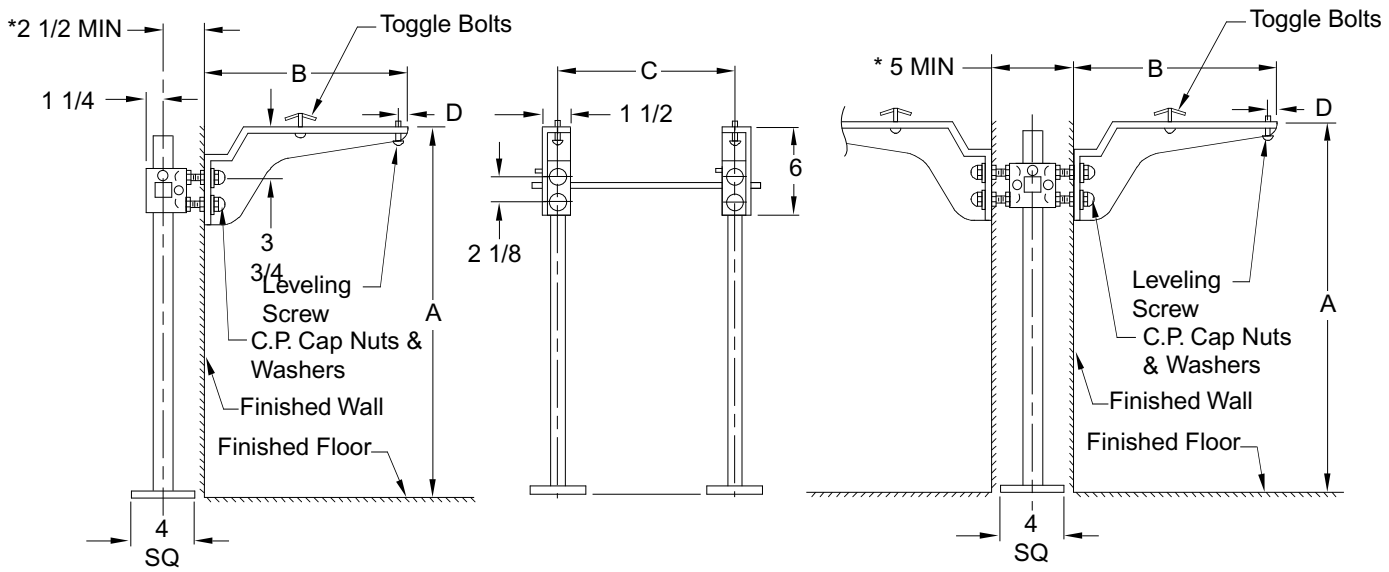
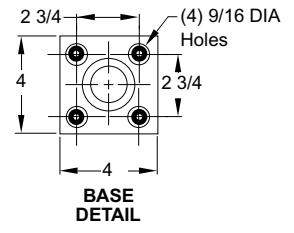

**Fig. 0751... WITH ACID RESISTANT COATED EXPOSED ARMS FOR FLAT SLAB AND HIGH BACK LAVATORIES**  
**Fig. 0751D... WITH ACID RESISTANT COATED EXPOSED ARMS FOR FLAT SLAB AND HIGH BACK LAVATORIES**

\*This dimension can be increased when fixture support is to be installed behind the wall (specify when required and wall thickness).

**NOTE:** For metal stud wall construction, specify Suffix -M31 rectangular steel upright with welded bases for greater strength.

**NOTE:** The rough-in dimensions listed on this drawing are based on current information available to Jay R. Smith by the fixture manufacturers. We recommend that you verify these dimensions with the fixture manufacturer. We will not accept responsibility for rough-in dimension changes by the fixture manufacturer.



### ROUGHING-IN TABLE

FIXTURE MFG.	NAME	NUMBER	SIZE	A	B	C	D
CRANE	NORWICH	1-185	20 x 18	27 5/8	15	17 1/4	1/2
CRANE	NORWICH	1-194	18 x 15	27 3/4	11	15 3/4	1/2
CRANE	NORWICH	1-194, 1-206	20 x 18	27 5/8	15	16 1/4	1/2
CRANE	NORWICH	1-194	24 x 21	27 1/2	15	20 3/4	1/2
KOHLER	CHESAPEAKE	K-1746, 8	18 x 15	27 1/2	11	15	2
KOHLER	CHESAPEAKE	K-1746, 8	19 x 17	27 1/4	15	16	1/2
KOHLER	CHESAPEAKE	K-1746, 8	20 x 18	27 1/4	15	17	3
KOHLER	GREENWICH	K-2030, 1, 2, 4, 6	18 x 15	27 1/4	11	15 1/4	2
KOHLER	GREENWICH	K-2030, 1, 2, 4, 6	20 x 18	27 1/4	15	16 1/2	3
KOHLER	GREENWICH	K-2030, 1, 2, 4, 6	24 x 20	27 1/4	15	19	1/2

DRAWING NUMBER  
S0751

SIZE  
A

SCALE:  
NONE

DATE:  
12-12-74

APPROVED BY:

CHECKED BY:

DRAWN BY:  
RAS

0751, 0751D

WE CAN ASSUME NO RESPONSIBILITY FOR USE OF SUPERSEDED OR VOID DATA

DIMENSIONS ARE SUBJECT TO MANUFACTURERS TOLERANCE AND CHANGE WITHOUT NOTICE

E	9-23-94	Submittal Update	EMB	BS	WEIGHT POUNDS	VOLUME CUBIC FEET	FIGURE NUMBER
REV.	DATE	DESCRIPTION	BY	CKD. BY			<b>0751, 0751D</b>