

G



JAY R. SMITH MFG. CO.
 DIVISION OF SMITH INDUSTRIES, INC.
 POST OFFICE BOX 3237
 MONTGOMERY, ALABAMA 36109-0237 (USA)
 TEL: 334-277-8520 FAX: 334-272-7396 www.jrsmith.com



MEMBER OF:

LOCATION

LAVATORY SUPPORTS WITH CONCEALED ARMS

WALL MOUNTED

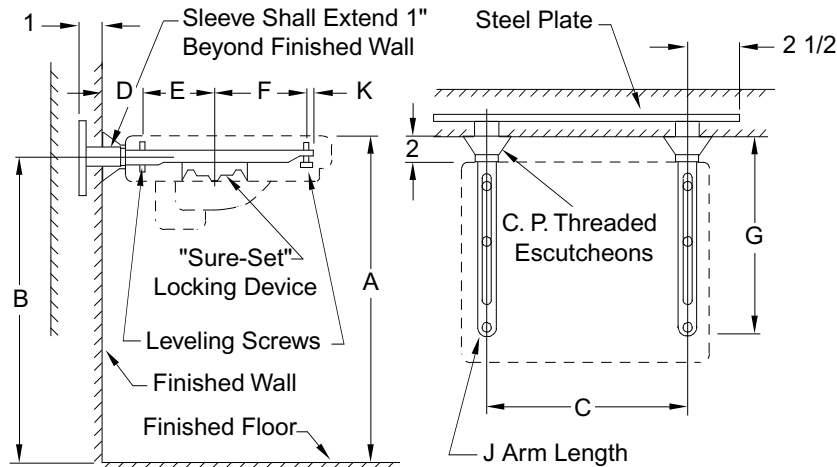

Fig. 0722 (-E) . . . FOR FLAT SLAB LAVATORIES SET ON STEEL PLATE SECURED IN WALL

ROUGHING-IN TABLE

FIXTURE MFG.	NAME	NUMBER	SIZE	A	B	C	D	E	F	G	J	K
AM. STD.	ROXALYN	0194.076	20 x 18	31	29 1/4	16 1/2	4	7	7	18 1/2	20	1/2
AM. STD.	ROXALYN	0194.134	24 x 20	31	29 1/4	20	4	7	7	18 1/2	20	1/2
AM. STD.	ROXALYN	0195.073	20 x 18	31	29 1/4	16 1/2	4	7	7	18 1/2	20	1/2
AM. STD.	ROXALYN	0195.289	24 x 20	31	29 1/4	20	4	7	7	18 1/2	20	1/2
CRANE	NORWICH	1-165	20 x 18	31	29 1/8	16 1/4	4	5 5/8	6 3/8	18 1/2	20	2 1/2
CRANE	NORWICH	1-165	24 x 21	31	29 1/8	19 1/2	4	5 5/8	7 1/8	18 1/4	20	1 1/2
ELJER	MAYBURNE	051-2344, 2548	20 x 18	31	29	17	4	5 5/8	5 5/8	17 1/4	19	2
ELJER	MAYBURNE	051-2354, 2558	24 x 20	31	29	20 7/8	4	5 5/8	7 1/8	18 1/4	20	1 1/2
KOHLER	JAMESTOWN	K-2053, 4, 5, 6	20 x 18	31	29	16 1/2	4	5 5/8	5 5/8	17 1/4	19	2
KOHLER	JAMESTOWN	K-2053, 4, 5, 6	24 x 20	31	29	19	4	7	7	18 1/2	20	1/2
U. RUNDLE	NEW CAMPUS	4698, 9	20 x 18	31	29 3/8	16 1/4	4	5	4	14	16	1

NOTE: The rough-in dimensions listed on this drawing are based on current information available to Jay R. Smith by the fixture manufacturers. We recommend that you verify these dimensions with the fixture manufacturer. We will not accept responsibility for rough-in dimension changes by the fixture manufacturer.

DRAWING NUMBER
S0722 (-E)SIZE
ASCALE:
NONEDATE:
1-26-73

APPROVED BY:

CHECKED BY:
RPDRAWN BY:
JH

0722 (-E)

FIGURE
NUMBER

WE CAN ASSUME NO RESPONSIBILITY FOR USE OF SUPERSEDED OR VOID DATA

DIMENSIONS ARE SUBJECT TO MANUFACTURERS TOLERANCE AND CHANGE WITHOUT NOTICE

G
F
E9-22-94
12-13-74
1-26-73Submittal Update
Rev Table
New DwgEMB
BDS
JH

BS

WEIGHT
POUNDSVOLUME
CUBIC FEET

FIGURE NUMBER

0722 (-E)

REV.

DATE

DESCRIPTION

BY

CKD. BY

H



JAY R. SMITH MFG. CO.
 DIVISION OF SMITH INDUSTRIES, INC.
 POST OFFICE BOX 3237
 MONTGOMERY, ALABAMA 36109-0237 (USA)
 TEL: 334-277-8520 FAX: 334-272-7396 www.jrsmith.com



MEMBER OF:

LOCATION

LAVATORY SUPPORTS WITH CONCEALED ARMS

WALL MOUNTED

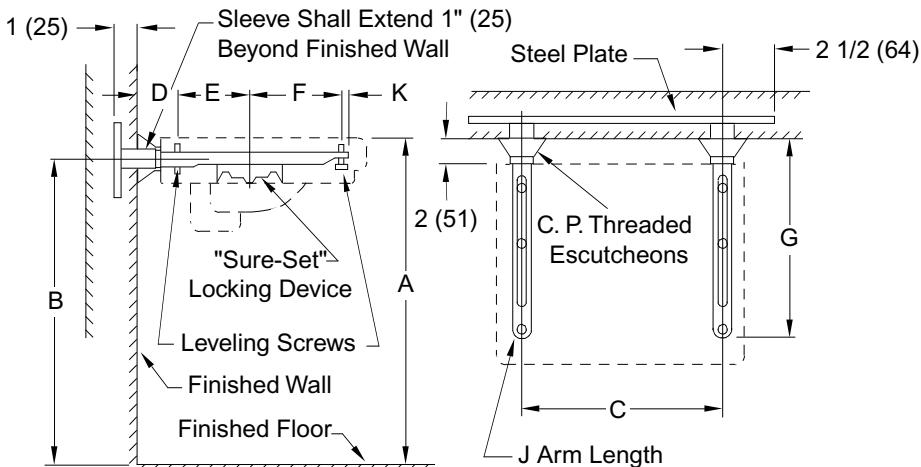

Fig. 0722 (-E) . . . FOR FLAT SLAB LAVATORIES SET ON STEEL PLATE SECURED IN WALL

ROUGHING-IN TABLE

FIXTURE NAME				NUMBER			SIZE	
A	B	C	D	E	F	G	J	K

NOTE: The rough-in dimensions listed on this drawing are based on current information available to Jay R. Smith by the fixture manufacturers. We recommend that you verify these dimensions with the fixture manufacturer. We will not accept responsibility for rough-in dimension changes by the fixture manufacturer.

NOTE: Dimensions shown in parentheses are in millimeters.

DRAWING NUMBER
S0722 (-E) (B)

SIZE
A

SCALE:
NONE

DATE:
1-7-81

APPROVED BY:

CHECKED BY:
TD

DRAWN BY:
TD

0722 (-E)

WE CAN ASSUME NO RESPONSIBILITY FOR USE OF SUPERSEDED OR VOID DATA

DIMENSIONS ARE SUBJECT TO MANUFACTURERS TOLERANCE AND CHANGE WITHOUT NOTICE

H G F E	4-2-97 9-22-94 12-13-74 1-26-73	Added Millimeters Submittal Update Rev Table New Dwg	EMB EMB BDS JH	BS BS	WEIGHT POUNDS	VOLUME CUBIC FEET	FIGURE NUMBER 0722 (-E)
REV.	DATE	DESCRIPTION	BY	CKD. BY			