

P

SMITH® JAY R. SMITH MFG. CO.®
 DIVISION OF SMITH INDUSTRIES, INC.
 POST OFFICE BOX 3237
 MONTGOMERY, ALABAMA 36109-0237 (USA)
 TEL: 334-277-8520 FAX: 334-272-7396 www.jrsmith.com



MEMBER OF:

LOCATION

LAVATORY SUPPORTS WITH CONCEALED ARMS

FLOOR MOUNTED WITH "PRO-SET" UPRIGHTS

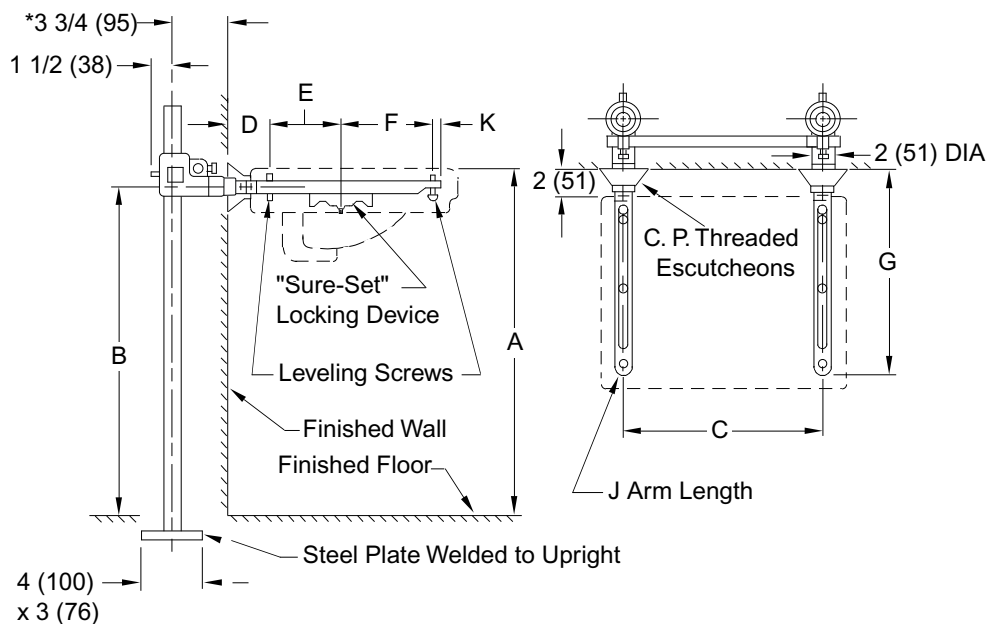
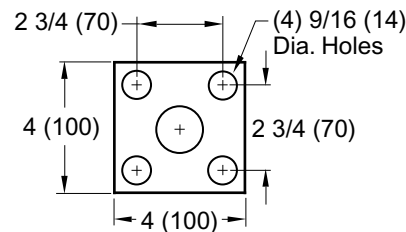

Fig. 0700 (-E) . . . FOR FLAT SLAB LAVATORIES (shown)

NOTE: The rough-in dimensions listed on this drawing are based on current information available to Jay R. Smith by the fixture manufacturers. We recommend that you verify these dimensions with the fixture manufacturer. We will not accept responsibility for rough-in dimension changes by the fixture manufacturer.

NOTE: *This dimension can be increased when fixture support is to be installed behind the wall. (Specify when required and wall thickness).

NOTE: Dimensions shown in parentheses are in millimeters.



BASE DETAIL

ROUGHING-IN TABLE

FIXTURE MFG.	NAME	NUMBER	SIZE	A	B	C	D	E	F	G	J	K
AM. STD.	ROXALYN	0194.076	20 (510) x 18 (455)	31 (785)	29 1/4 (745)	16 1/2 (420)	4 (100)	7 (180)	7 (180)	18 1/2 (470)	20 (510)	1/2 (13)
AM. STD.	ROXALYN	0194.134	24 (610) x 20 (510)	31 (785)	29 1/4 (745)	20 (510)	4 (100)	7 (180)	7 (180)	18 1/2 (470)	20 (510)	1/2 (13)
AM. STD.	ROXALYN	0195.073	20 (510) x 18 (455)	31 (785)	29 1/4 (745)	16 1/2 (420)	4 (100)	7 (180)	7 (180)	18 1/2 (470)	20 (510)	1/2 (13)
AM. STD.	ROXALYN	0195.289	24 (610) x 20 (510)	31 (785)	29 1/4 (745)	20 (510)	4 (100)	7 (180)	7 (180)	18 1/2 (470)	20 (510)	1/2 (13)
CRANE	NORWICH	1-165	20 (510) x 18 (455)	31 (785)	29 1/8 (740)	16 1/4 (415)	4 (100)	5 5/8 (143)	6 3/8 (162)	18 1/2 (470)	20 (510)	2 1/2 (64)
CRANE	NORWICH	1-165	24 (610) x 21 (535)	31 (785)	29 1/8 (740)	19 1/2 (495)	4 (100)	5 5/8 (143)	7 1/8 (181)	18 1/4 (465)	20 (510)	1 1/2 (38)
ELJER	MAYBURNE	051-2241, 4, 5, 8	20 (510) x 18 (455)	34 (865)	29 (735)	17 (430)	4 (100)	5 5/8 (143)	5 5/8 (143)	17 1/4 (440)	19 (485)	2 (51)
U. RUNDLE	NEW CAMPUS	4698, 9	20 (510) x 18 (455)	31 (785)	29 3/8 (746)	16 1/4 (415)	4 (100)	5 (125)	4 (100)	14 (355)	16 (405)	1 (25)

DRAWING NUMBER
S0700 (-E)

SIZE
A

SCALE:
NONE

DATE:
12-12-74

APPROVED BY:

CHECKED BY:
RS

DRAWN BY:
RAS

0700 (-E)

WE CAN ASSUME NO RESPONSIBILITY FOR USE OF SUPERSEDED OR VOID DATA

DIMENSIONS ARE SUBJECT TO MANUFACTURERS TOLERANCE AND CHANGE WITHOUT NOTICE

FIGURE NUMBER	P N M L	03/07/02 01/12/02 2/20/01 01/12/00	Revised Roughing-in Table Revised Submittal Revised Submittal Revised Base Plate	JJ JJ RN JJ	AM AM BS	WEIGHT POUNDS	VOLUME CUBIC FEET	FIGURE NUMBER 0700 (-E)
REV.	DATE	DESCRIPTION	BY	CKD. BY				



MEMBER OF:

LOCATION

INSTALLATION INSTRUCTIONS FOR CONCEALED ARM CARRIERS

BEFORE starting rough-in be certain you:
 a) know correct fixture number and name
 b) have a copy of Smith submittal (rough-in) drawing with dimensions for fixture to be used.

NOTE: The rough-in dimensions listed on this drawing are based on current information available to Jay R. Smith by the fixture manufacturers. We recommend that you verify these dimensions with the fixture manufacturer. We will not accept responsibility for rough-in dimension changes by the fixture manufacturer.

PART	QTY	DESCRIPTION
1	2	Upright (w/welded base)
2	2	Sleeve Assembly
3	1	Alignment Bar
4	2	Locking Coupling
5	2	Escutcheon Fig. 0700 (-E)
6	2	Arm Assembly
6a	2	Rear Leveling Screw Assy
6b	2	Locking Device
6c	2	Front Leveling Screw

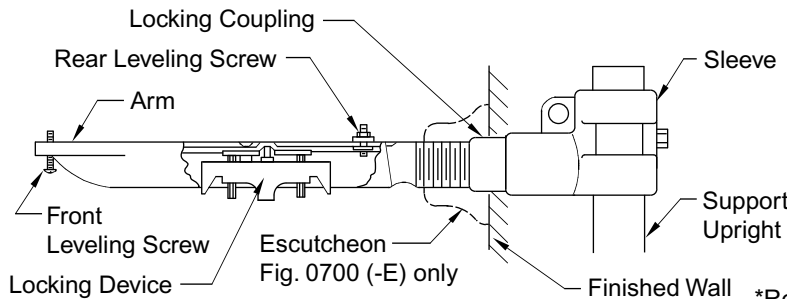
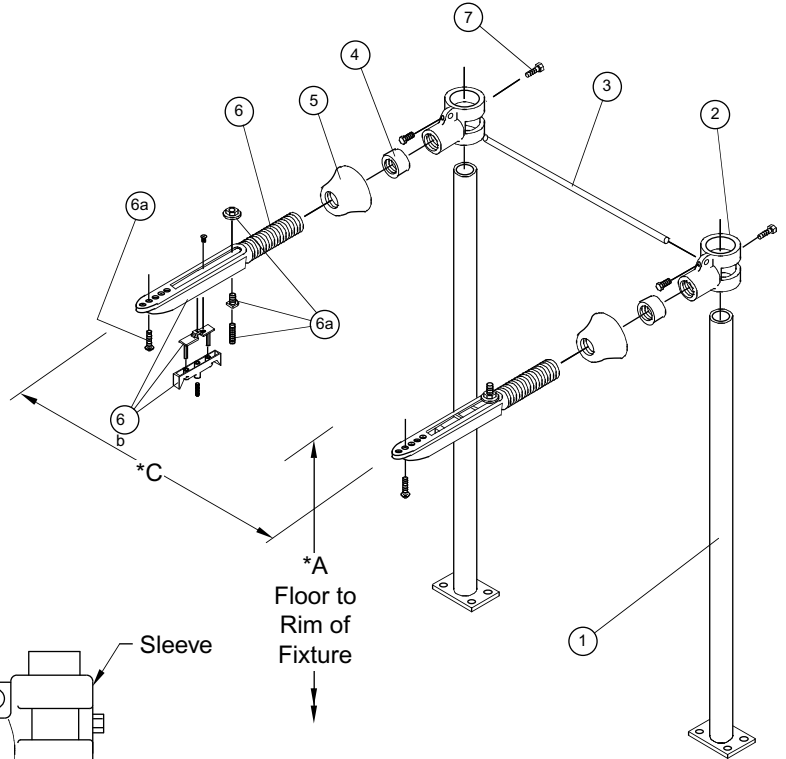

*Refer to Smith submittal drawing for these dimensions.

INSTALLATION INSTRUCTIONS FOR CONCEALED ARM CARRIERS

1. Uprights (Part #1) must be spaced according to the "C" dimension (shown on the submittal drawing). Uprights should not be bolted rigidly to the floor at this time.
2. Position sleeves (Part #2) by using the "B" dimension (shown on the submittal drawing). Secure to uprights with 5/16 (8)-18 hex head bolts (furnished) on the back of the sleeve.
3. Slide alignment bar (Part #3) into the sleeves. Recheck the "C" dimension at the center of the uprights. Secure the alignment bar with 5/16 (8) hex head bolts (furnished). Uprights should now be bolted securely to the floor. Uprights must be plumb: if necessary, shim to compensate for uneven floors.
4. Thread escutcheon (Part #5), Fig. 0700 (-E) only onto arm (Part #6). Thread locking coupling (Part #4) onto arm. Thread arms into sleeves (Part #2) to dimension "G" (shown on the submittal drawing). Lock arms in place by tightening locking coupling (Part #4). Recheck "C" dimension at the end of the arms.
5. Rear leveling screw assemblies (Part #6a) must be set according to the "D" dimension (shown on the submittal drawing). Position the locking devices (Part #6b) to the "E" dimension (shown on the submittal drawing). Install the front leveling screws (Part #6c) to the "E" dimension (shown on the submittal drawing).
6. Level lavatory with leveling screws as required and secure in place with locking device.

DRAWING NUMBER
S0700 INS

SIZE
A

SCALE:
NONE

DATE:
8-8-85

APPROVED BY:
KG

CHECKED BY:
CR

DRAWN BY:
VGD

FIGURE NUMBER
0700, 0700 (-E)
INSTALLATION INSTRUCTIONS

WE CAN ASSUME NO RESPONSIBILITY FOR USE OF SUPERSEDED OR VOID DATA

D	2/16/01	Revised Submittal	RN	BS	WEIGHT POUNDS	VOLUME CUBIC FEET	FIGURE NUMBER 0700, 0700 (-E) INSTALLATION INSTRUCTIONS
C	01/11/00	Revised Base Plate	JJ	BS			
B	6-7-95	Added Millimeters	EMB	BS			
A	9-27-94	Submittal Update					
REV.	DATE	DESCRIPTION	BY	CKD. BY			

LAVATORY SUPPORTS WITH CONCEALED ARMS

FLOOR MOUNTED WITH "PRO-SET" UPRIGHTS

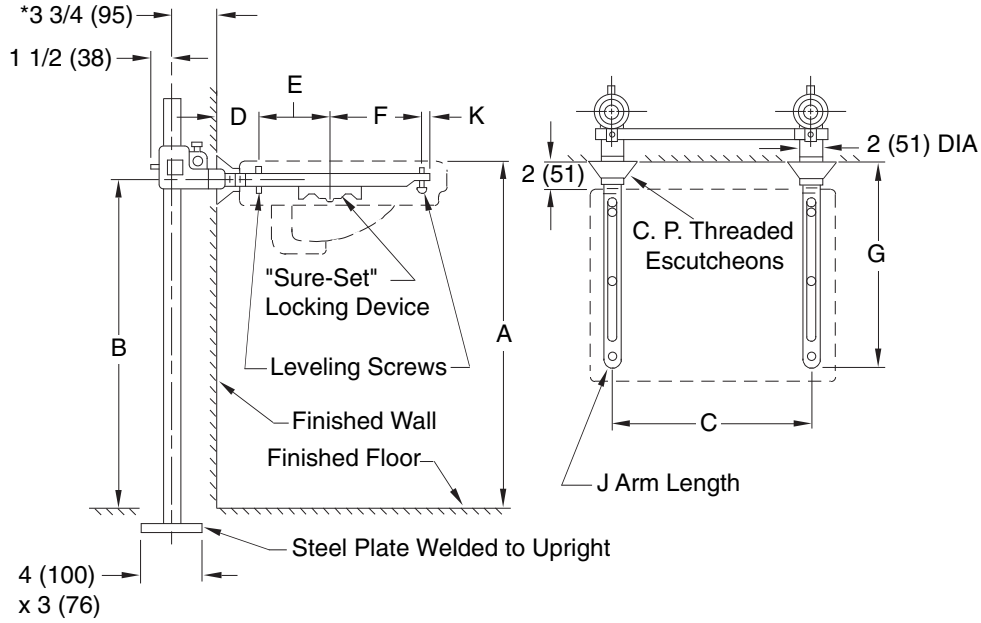
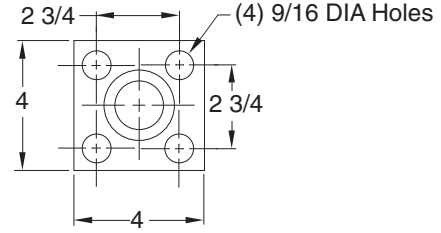

Fig. 0700 (-E) . . . FOR FLAT SLAB LAVATORIES (shown)

NOTE: The rough-in dimensions listed on this drawing are based on current information available to Jay R. Smith by the fixture manufacturers. We recommend that you verify these dimensions with the fixture manufacturer. We will not accept responsibility for rough-in dimension changes by the fixture manufacturer.



BASE DETAIL

ROUGHING-IN TABLE

		FIXTURE NAME			NUMBER			SIZE	
A	B	C	D	E	F	G	J	K	

NOTE: *This dimension can be increased when fixture support is to be installed behind the wall. (Specify when required and wall thickness).

NOTE: Dimensions shown in parentheses are in millimeters.

0700 (-E)

DIMENSIONS ARE SUBJECT TO MANUFACTURERS TOLERANCE AND CHANGE WITHOUT NOTICE

WE CAN ASSUME NO RESPONSIBILITY FOR USE OF SUPERSEDED OR VOID DATA

DRAWING NUMBER
S0700 (-E) (B)

SIZE
A

SCALE:
NONE

DATE:
9-11-63

APPROVED BY:
RP

CHECKED BY:
RP

DRAWN BY:
SL

FIGURE NUMBER

B	6-7-95	Added Millimeters Submittal Update	EMB	BS	WEIGHT POUNDS	VOLUME CUBIC FEET	FIGURE NUMBER
REV.	DATE	DESCRIPTION	BY	CKD. BY			0700 (-E)