

SMITH® JAY R. SMITH MFG. CO.
 DIVISION OF SMITH INDUSTRIES, INC.
 POST OFFICE BOX 3237
 MONTGOMERY, ALABAMA 36109-0237 (USA)
 TEL: 334-277-8520 • FAX: 334-272-7396 • www.JRSmith.com

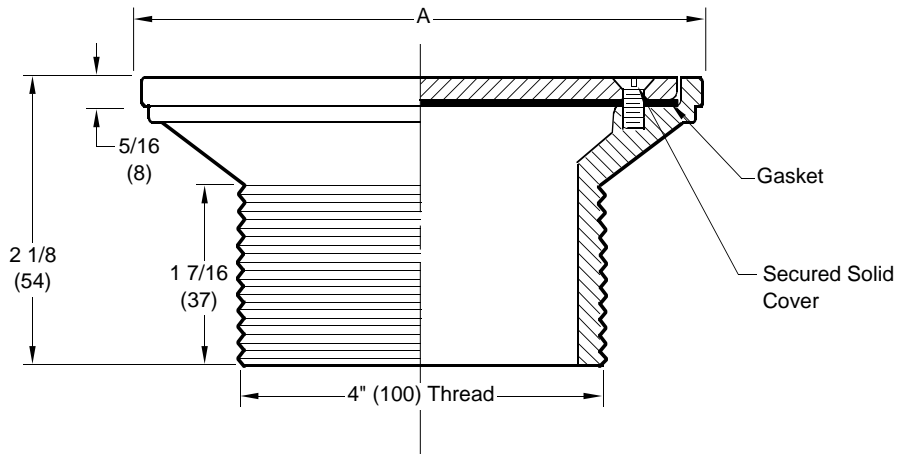

LOCATION

ADJUSTABLE CLEANOUT

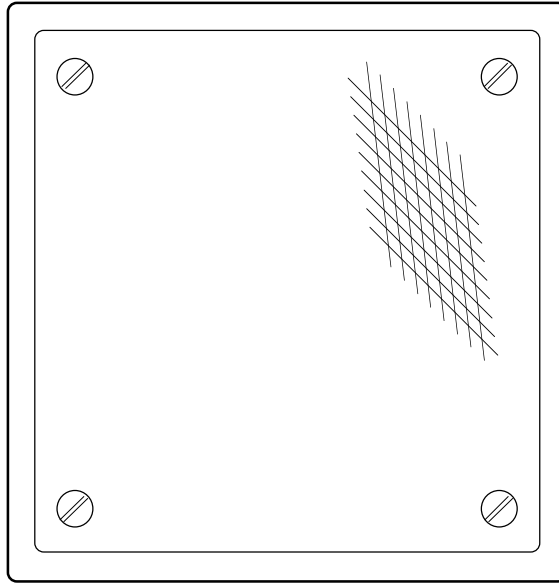

NOTE: Dimensions shown in parentheses are in millimeters.

Strainer Size	"A" Square
06 (150)	6 x 6 (150 x 150)

REGULARLY FURNISHED:
 Nickel Bronze Strainer with Satin
 Nickel Bronze Secured Solid
 Gasket Cover. 4"(100) NPSM
 Threaded Shank.

VARIATIONS:
 (12) SQ Hole Grate
 BSP Threads
 Vandal Proof Top -U

OPTIONAL MATERIALS:
 Chrome Plated -CP
 Polished Bronze -PB
 Rough Bronze -RB

DRAWING NUMBER
SQ-4-1454

SIZE
A

SCALE:
NONE

DATE:
10-19-92

APPROVED BY:
SB

CHECKED BY:
McD

DRAWN BY:
TWK

FIGURE NUMBER
SQ-4-1454

WE CAN ASSUME NO RESPONSIBILITY FOR USE OF SUPERSEDED OR VOID DATA

REV.	DATE	DESCRIPTION	BY	CKD. BY	WEIGHT POUNDS	VOLUME CUBIC FEET	FIGURE NUMBER
B	11-3-97	Updated Millimeters	EMB	BS			SQ-4-1454
A	1-27-94	Added 12MM & BSP Var.	TWK	GWC			