

D

DRAWING NUMBER
SSQ-4-1453

SIZE
A

SCALE:
NONE

DATE:
10-19-92

APPROVED BY:
SJM

CHECKED BY:
McD

DRAWN BY:
TWK

FIGURE NUMBER
SQ-4-1453

LOCATION

ADJUSTABLE CLEANOUT

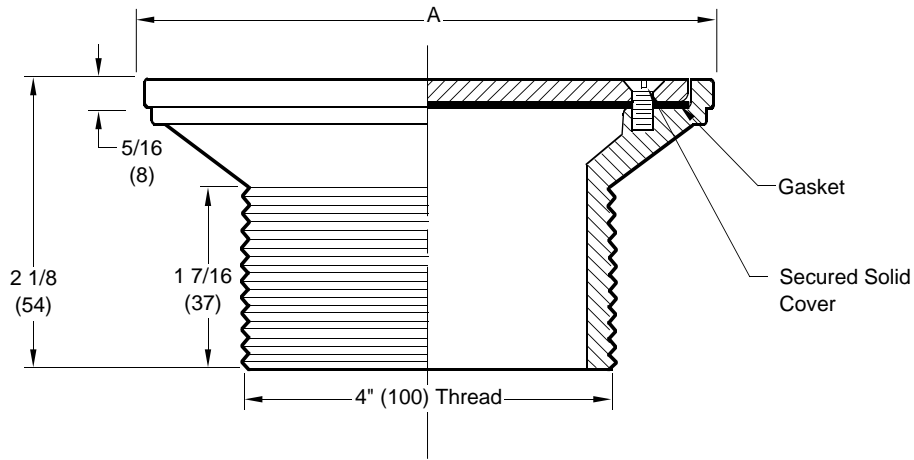
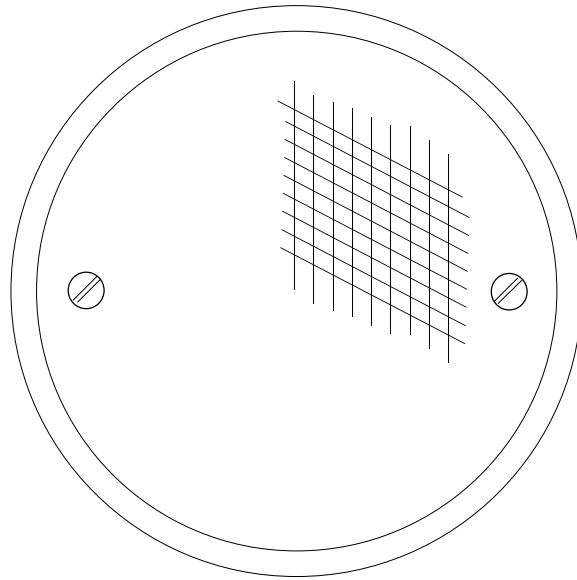

Strainer Size	"A" Round
06 (150)	6 Dia. (150)

NOTE: Dimensions shown in parentheses are in millimeters.

REGULARLY FURNISHED:
 Nickel Bronze Strainer with Satin
 Nickel Bronze Secured Solid
 Gasket Cover. 4"(100) NPSM
 Threaded Shank.

VARIATIONS:
 (12) SQ Hole Grate
 Threaded Shank 4"(100) BSP
 Vandal Proof Top -U

OPTIONAL MATERIALS:
 Chrome Plated -CP
 Polished Bronze -PB
 Rough Bronze -RB

REV.	DATE	DESCRIPTION	BY	CKD. BY	WEIGHT POUNDS	VOLUME CUBIC FEET	FIGURE NUMBER
D	11-3-97	Updated Millimeters	EMB	BS			SQ-4-1453
C	7-12-96	Chg'd Reg Furn and Var	EMB	SB			
B	12-14-95	Rev Reg Furn & Var	EMB	SB			
A	1-27-94	Added 12mm & BSP Var.	TWK	GWC			

DIMENSIONS ARE SUBJECT TO MANUFACTURERS TOLERANCE AND CHANGE WITHOUT NOTICE WE CAN ASSUME NO RESPONSIBILITY FOR USE OF SUPERSEDED OR VOID DATA