

B



**JAY R. SMITH MFG. CO.**  
 DIVISION OF SMITH INDUSTRIES, INC.  
 POST OFFICE BOX 3237  
 MONTGOMERY, ALABAMA 36109-0237 (USA)  
 TEL: 334-277-8520 FAX: 334-272-7396 www.jrsmith.com



MEMBER OF:



LOCATION

DRAWING NUMBER  
s8176GG

SIZE  
A

SCALE:  
NONE

DATE:  
3-6-07

APPROVED BY:  
CL

CHECKED BY:  
CL

DRAWN BY:  
RN

8176GG

FIGURE NUMBER

WE CAN ASSUME NO RESPONSIBILITY FOR USE OF SUPERSEDED OR VOID DATA  
DIMENSIONS ARE SUBJECT TO MANUFACTURERS TOLERANCE AND CHANGE WITHOUT NOTICE

## GREASE+GARD® RETROFIT SKIMMER LOW PROFILE TYPE FOR LOW TYPE GREASE INTERCEPTOR

**FUNCTION:** Designed for installation on an existing grease interceptor for the purpose of converting it to an automatic grease removal device (GRD). The unique design of the Grease+Gard® removes grease from the interceptor and discharges it into a reservoir for convenient disposal without having to remove the cover.

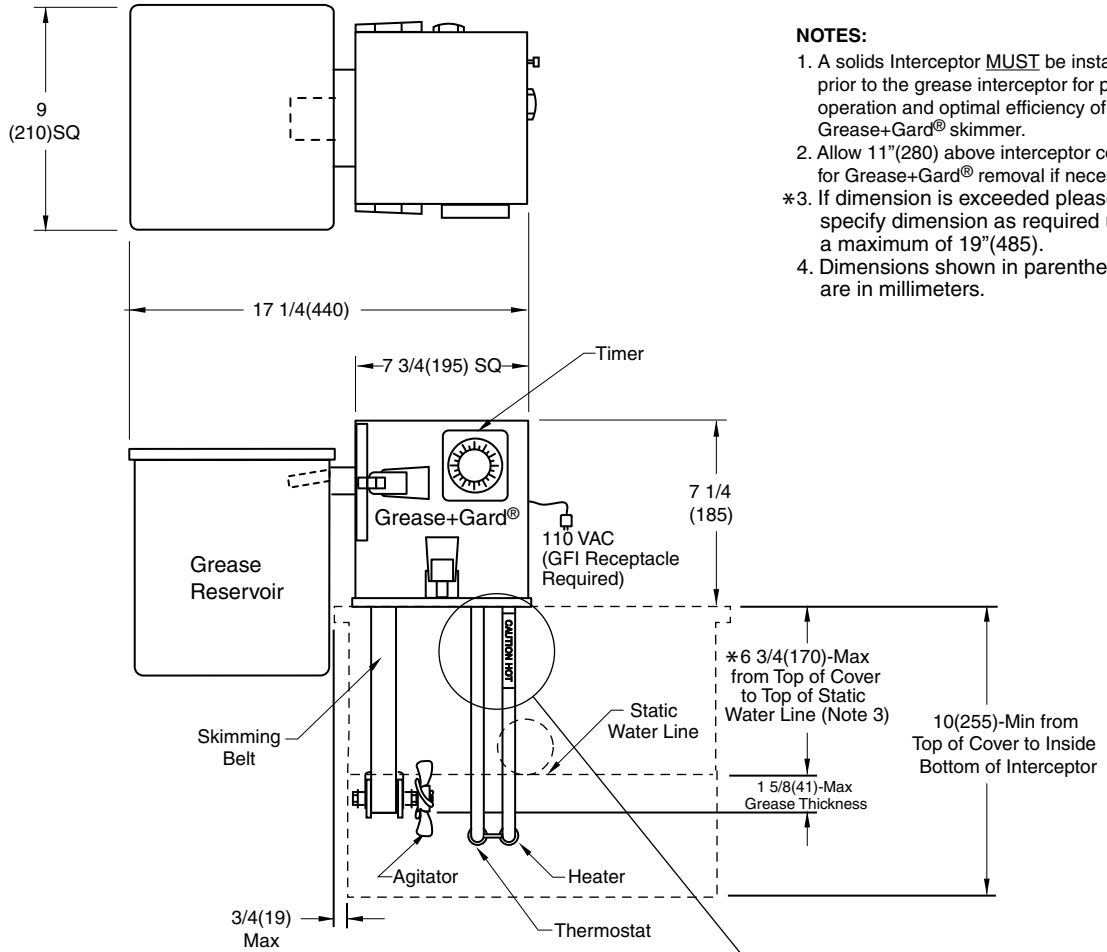

**NOTES:**

1. A solids Interceptor **MUST** be installed prior to the grease interceptor for proper operation and optimal efficiency of the Grease+Gard® skimmer.
2. Allow 11"(280) above interceptor cover for Grease+Gard® removal if necessary.
- \*3. If dimension is exceeded please specify dimension as required up to a maximum of 19"(485).
4. Dimensions shown in parentheses are in millimeters.

**REGULARLY FURNISHED:**  
 Low Profile Stainless Steel Housing, Adjustable Timer, Skimming Belt, Heater with Thermostat, Mounting Base with Gasket and Removable Grease Reservoir.

See reverse side for installation instructions.

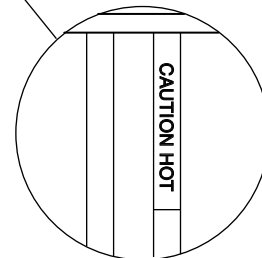

REV.	DATE	DESCRIPTION	BY	CKD. BY
B	09/04/07	Rev. Note 3 Added @ to Grease+Gard	JJ	CL
A	4-9-07		RN	CL

WEIGHT POUNDS	VOLUME CUBIC FEET	FIGURE NUMBER
		<b>8176GG</b>



**JAY R. SMITH MFG. CO.®**  
 DIVISION OF SMITH INDUSTRIES, INC.  
 POST OFFICE BOX 3237  
 MONTGOMERY, ALABAMA 36109-0237 (USA)  
 TEL: 334-277-8520 FAX: 334-272-7396 www.jrsmith.com



LOCATION

DRAWING NUMBER  
s8176GGBS

SIZE  
A

SCALE:  
NONE

DATE:  
3-6-07

APPROVED BY:  
CL

CHECKED BY:  
CL

DRAWN BY:  
RN

**8176GG**

WE CAN ASSUME NO RESPONSIBILITY FOR USE OF SUPERSEDED OR VOID DATA

## GREASE+GARD® RETROFIT SKIMMER LOW PROFILE TYPE FOR LOW TYPE GREASE INTERCEPTOR

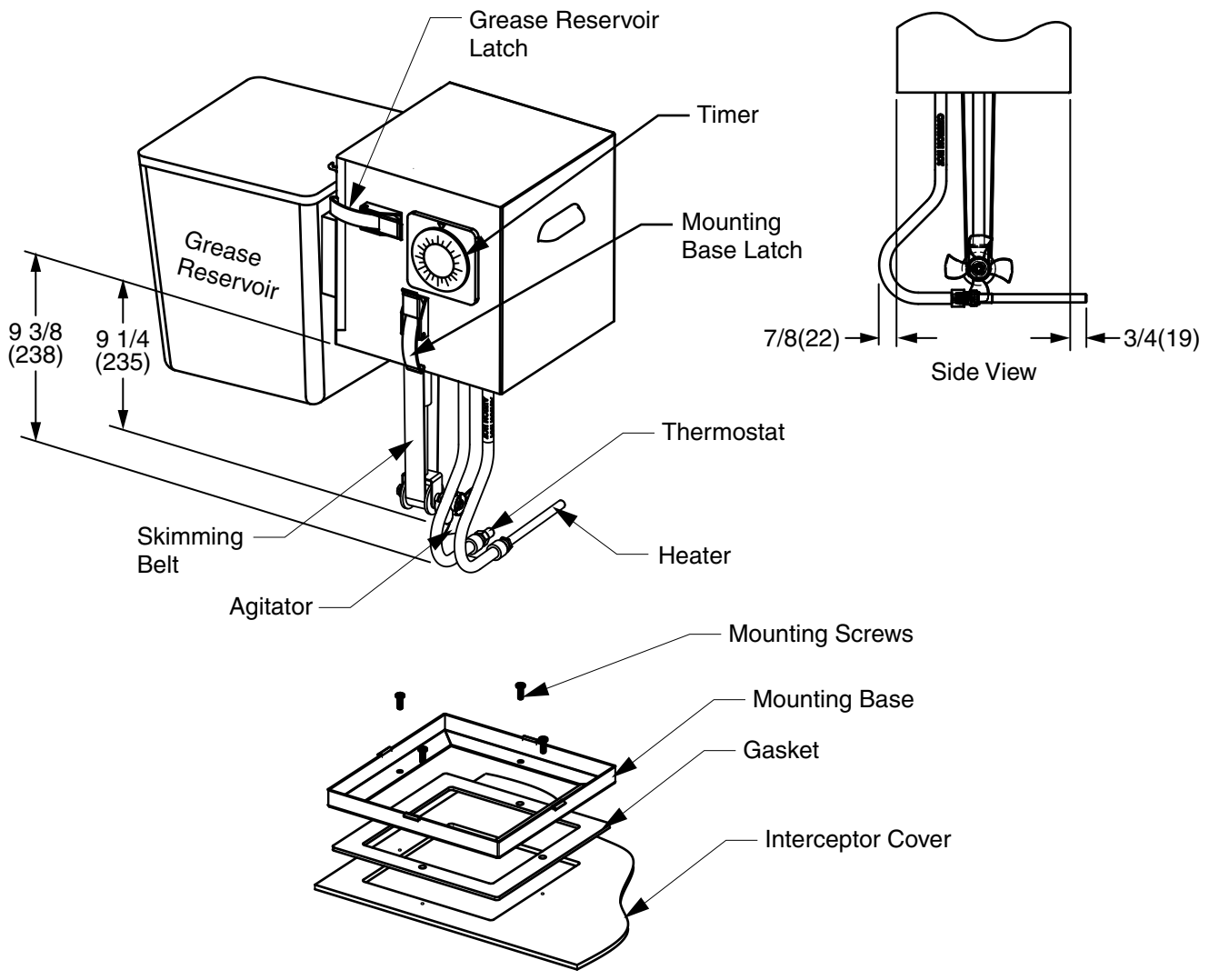

**Installation Instructions:**

1. Remove mounting base from the 8176GG by undoing the 2 latches on the sides down at the bottom.
2. Locate mounting base on the grease interceptor cover in a location where the grease skimming belt and heater element are unobstructed and clear of internal interceptor parts and so the grease reservoir will hang over the side of the interceptor.
3. Using the mounting base as template, mark the cover for appropriate opening to be cut and securing screw hole locations using the internal opening edges and securing holes of base as guide.
4. Cut opening in cover and drill and tap for 1/4-20 securing screws.
5. Place mounting base with gasket on cover over opening, positioning it where the timer and grease reservoir of the Grease+Gard® will be easily accessible and align with securing holes and secure using screws provided.
6. Place the Grease+Gard® skimmer housing in the base and secure using the 2 latches on the sides.
7. Plug power cord into 110 VAC power source with GFI.
8. Set timer according to instructions provided with unit.

**NOTE:** Dimensions shown in parentheses are in millimeters.

A	4-9-07	Added ® to Grease+Gard	RN	CL
REV.	DATE	DESCRIPTION	BY	CKD. BY

WEIGHT POUNDS	VOLUME CUBIC FEET

**FIGURE NUMBER**  
**8176GG**