



JAY R. SMITH MFG. CO.
 MEMBER OF ACORN'S FAMILY OF COMPANIES
 POST OFFICE BOX 3237
 MONTGOMERY, ALABAMA 36109-0237 (USA)
 TEL: 334-277-8520 FAX: 334-272-7396 www.jrsmith.com



MEMBER OF:

LOCATION

EXPOSED 1/4 TURN NON-FREEZE "TWIN TEMP" WALL HYDRANT

FUNCTION: Provides positive non-freeze protection where water is required at the outside of the building. Ideal for use in food handling areas, dairies and other places where both hot and cold water are desired. 1/4 turn of the key allows full flow to be obtained.

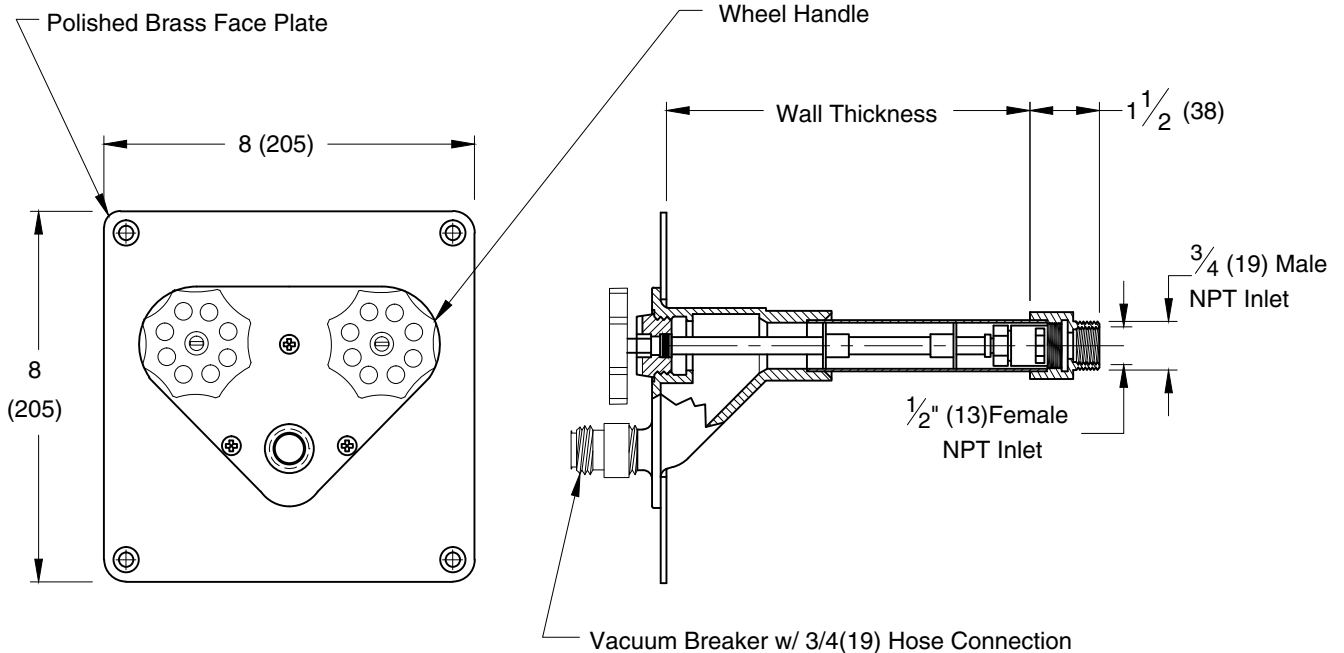

- Fig. 5660QT 1/2"(13) FEMALE & 3/4"(19) MALE INLET
- Fig. 5661QT 1"(25) MALE INLET

REGULARLY FURNISHED:

Bronze Quarter Turn Non-Freeze "Twin-Temp" Hydrant with 3/4"(19) Hose Connection, "T" Handle Key. Inlet Size Furnished as Indicated by Figure Number Selected.

VARIATIONS:

- Adjustable Wall Clamp -WC
- Wheel Handle -WH
- Vacuum Breaker Self Draining Type -H

OPTIONAL MATERIALS:

- Nickel Bronze Face -NB
- Chrome Plated Face -CP
- Rough Bronze Face -RB

NOTES:

1. Recommended wall opening 6"(150) x 6"(150).
2. When ordering, specify wall thickness in 2"(51) increments as follows: 6(150), 8(205), 10(255), 12(305), 14(355), 16(405), 18(455), 20(510), 22(560) or 24(610). When wall clamp -WC is desired, increase wall thickness dimension by 2"(51).
3. For hose to drain and provide non-freeze protection the hose MUST be removed from the hose connection.
4. All Jay R. Smith hydrants are manufactured with "NO-LEAD" brazing rings and USDA approved lubricants.
5. The AB1953, California Lead Law, and NSF/ANSI Standard 61-2008 - Drinking Water System Components are not applicable to Jay R. Smith hydrants as they do not convey/dispense water for human consumption through drinking or cooking.
6. Dimensions shown in parentheses are in millimeters.

DRAWING NUMBER
5660QT, 5661QT (-H-WH)

SIZE
A

SCALE:
NONE

DATE:
6-21-11

APPROVED BY:
CL

CHECKED BY:
CL

DRAWN BY:
TBW

5660QT (-H-WH)
5661QT (-H-WH)

WE CAN ASSUME NO RESPONSIBILITY FOR USE OF SUPERSEDED OR VOID DATA

DIMENSIONS ARE SUBJECT TO MANUFACTURERS TOLERANCE AND CHANGE WITHOUT NOTICE

REV.	DATE	DESCRIPTION	BY	CKD. BY

WEIGHT POUNDS	VOLUME CUBIC FEET	FIGURE NUMBER
		5660QT (-H-WH) 5661QT (-H-WH)