

NO-HUB VERTICAL OFFSET WASTE FITTING

FOR USE WITH FLOOR MOUNTED BACK OUTLET CLOSET

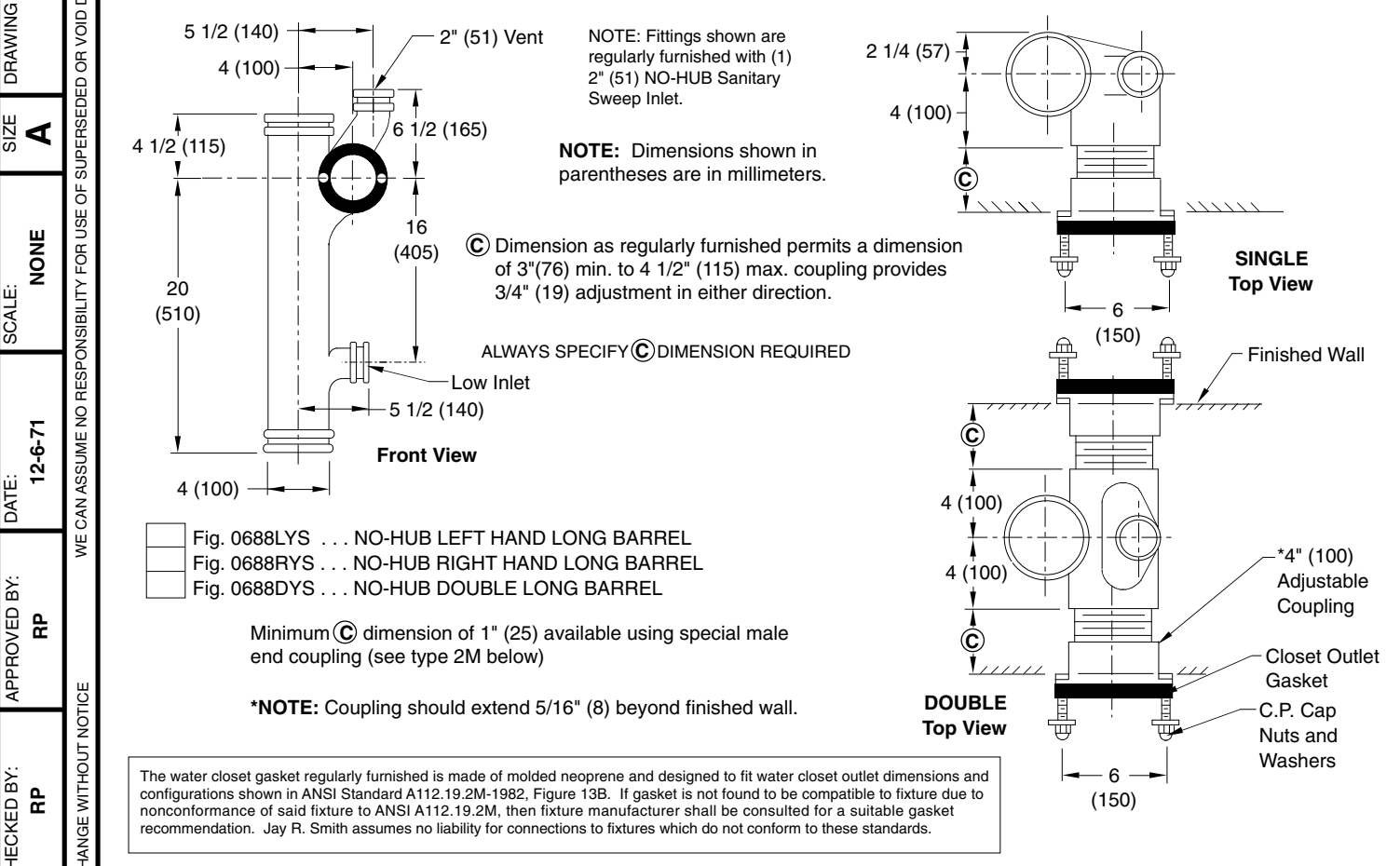

WE CAN ASSUME NO RESPONSIBILITY FOR USE OF SUPERSEDED OR VOID DATA

DIMENSIONS ARE SUBJECT TO MANUFACTURERS TOLERANCE AND CHANGE WITHOUT NOTICE

TYPICAL APPLICATION

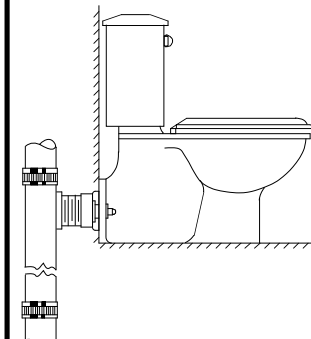

OUTLET CONNECTIONS

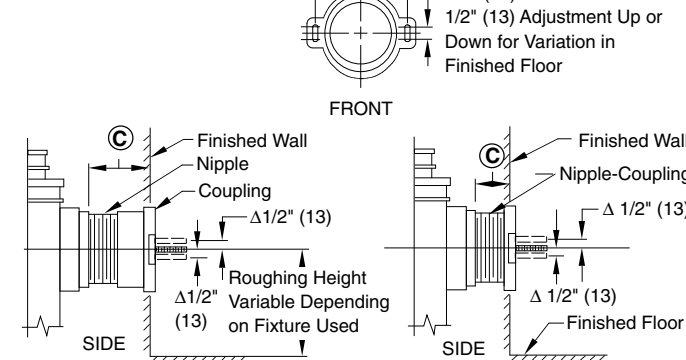

REGULARLY FURNISHED **TYPE 2M (When Specified)**

NIPPLE LENGTHS AVAILABLE

NIPPLE LENGTH	MIN	©	MAX
2 1/2 (64)	2 3/4 (70)	3 3/4 (95)	
*3 1/4 (83)	3 (76)	4 1/2 (115)	
4 1/2 (115)	4 1/4 (110)	5 3/4 (145)	
5 1/4 (135)	5 (125)	6 1/2 (165)	
6 1/4 (160)	6 (150)	7 1/2 (190)	
7 (180)	6 3/4 (170)	8 1/4 (210)	
8 1/4 (210)	8 (205)	9 1/2 (240)	
10 (255)	9 3/4 (250)	11 1/4 (285)	
12 (305)	11 3/4 (300)	13 1/4 (335)	
15 (380)	14 3/4 (375)	16 1/4 (415)	
18 (455)	17 3/4 (450)	19 1/4 (490)	

* Regularly Furnished

FIGURE NUMBER	C B A	3-24-97 4-15-96 10-12-94	Changed "C"s Added Millimeters Submittal Update	EMB EMB CMB	BS BS BS	WEIGHT POUNDS	VOLUME CUBIC FEET	FIGURE NUMBER
REV.	DATE	DESCRIPTION	BY	CKD. BY				0688YS