



JAY R. SMITH MFG. CO.
 DIVISION OF SMITH INDUSTRIES, INC.
 POST OFFICE BOX 3237
 MONTGOMERY, ALABAMA 36109-0237 (USA)
 TEL: 334-277-8520 FAX: 334-272-7396 www.jrsmith.com



LOCATION

LABOR SAVER URINAL SUPPORTS FOR OFF-THE-FLOOR URINALS

WITH SUPPORTING STUDS AND WASTE FITTING, ADJUSTABLE COUPLING

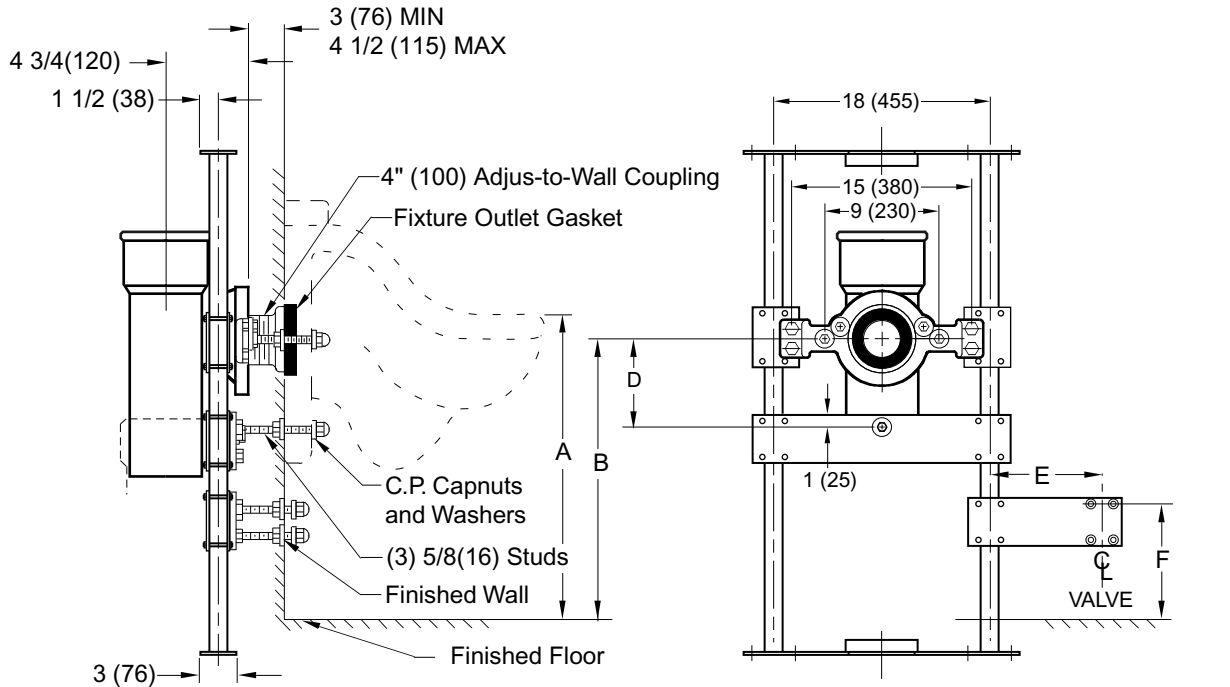

NOTE: The rough-in dimensions listed on this drawing are based on current information available to Jay R. Smith by the fixture manufacturers. We recommend that you verify these dimensions with the fixture manufacturer. We will not accept responsibility for rough-in dimension changes by the fixture manufacturer.

NOTE: The water closet gasket regularly furnished is made of molded neoprene and designed to fit water closet outlet dimensions and configurations shown in ANSI Standard A112.19.2M-1982, Figure 13B. If gasket is not found to be compatible to fixture due to nonconformance of said fixture to ANSI A112.19.2M, then fixture manufacturer shall be consulted for a suitable gasket recommendation. Jay R. Smith assumes no liability for connections to fixtures which do not conform to these standards.

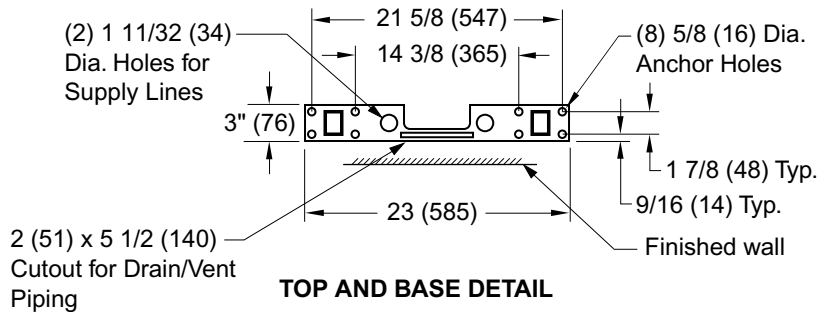

ROUGH-IN TABLE

FIXTURE MFG.	NAME	NUMBER	SIZE	A	B	D	E	F

NOTE: Dimensions shown in parenthesis are in millimeters.

Specify size and type of fitting.

- 4" (100) CAULK WITH 2" (76) VENT
- 4" (100) CAULK WITH 4" (100) VENT

DRAWING NUMBER
S0611-KW

SIZE
A

SCALE:
NONE

DATE:
04/23/01

APPROVED BY:
AM

CHECKED BY:
CR

DRAWN BY:
JJ

0611-KW

FIGURE NUMBER

WE CAN ASSUME NO RESPONSIBILITY FOR USE OF SUPERSEDED OR VOID DATA

REV.	DATE	DESCRIPTION	BY	CKD. BY
B	12/05/02	Revised per George Flegel	JJ	AM
A	07/31/02	Revised View	JJ	AM

WEIGHT POUNDS
VOLUME CUBIC FEET

FIGURE NUMBER
0611-KW