

COMPACT FIXTURE SUPPORTS
FOR SIPHON JET WATER CLOSETS WITH VERTICAL OFFSET FITTINGS

FLOOR-MOUNT FRAME FOR HUB & SPIGOT SYSTEMS

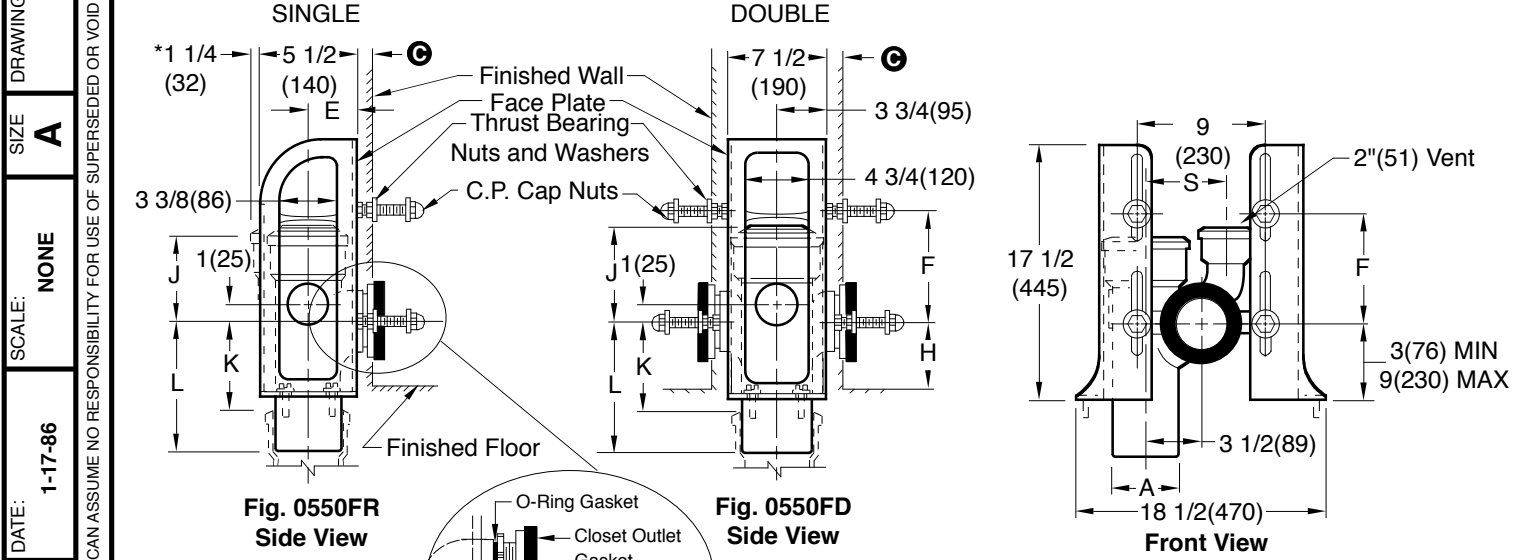

NOTE: The rough-in dimensions listed on this drawing are based on current information available to Jay R. Smith by the fixture manufacturers. We recommend that you verify these dimensions with the fixture manufacturer. We will not accept responsibility for rough-in dimension changes by the fixture manufacturer.

*Hub extends beyond frame 1 1/4"(32) for 4"(100) cast iron hub.

- Fig. 0550FL3 . . . 3"(80) CAULK Left Hand
- Fig. 0550FL4 . . . 4"(100) CAULK Left Hand
- Fig. 0550FR3 . . . 3"(80) CAULK Right Hand
- Fig. 0550FR4 . . . 4"(100) CAULK Right Hand
- Fig. 0550FD3 . . . 3"(80) CAULK Double
- Fig. 0550FD4 . . . 4"(100) CAULK Double

- NOTE:** Coupling should extend 5/16"(8) beyond finished wall.
- NOTE:** When using closet with bar hanger, add suffix-H to figure numbers shown.
- NOTE:** See roughing-in table on reverse side for "F" and "H" dimensions and list of compatible fixtures.
- NOTE:** Longer closet studs and couplings available when required.
- NOTE:** 1"(25) MIN to 1 1/4"(32) MAX regularly furnished. Other dimensions available upon request. Service weight regularly furnished.

A	E	J	K	L	S
3(80)	3(76)	6(150)	5 1/4(135)	8(205)	5 1/4(135)
4(100)	3 3/4(95)	6(150)	5(125)	8(205)	5 1/4(135)

INSTALLATION INSTRUCTIONS

- A. The center of the stack should be located by the "E" dimension shown on the table. "E" dimension for 0550FD is 3 3/4(95).
- B. To determine the height of the stack in relation to the finished floor, subtract the "H" dimension from the "K" dimension.
- C. The fitting should now be caulked into the stack.
- D. Assemble the faceplates temporarily to the fitting, mark the location of the bolt holes in the slab, and then secure faceplates to the floor.
- E. Faceplates are fastened to the arms of the adaptor by means of the fixture studs, nuts and washers provided.
- F. Thread locknut on male thread of adjustable coupling approximately 1"(25) and push "O"-Ring against locknut.
- G. Apply No. 90 Smith Seal to male threads on coupling. Install coupling and adjust it to extend 5/16"(8) beyond finished wall. Thread locknut snugly.
- H. Assemble the bearing nuts and washers to the fixture supporting studs. The fixture studs should extend 2 1/4"(57) beyond finished wall.
- I. Adjust bearing nuts so that washers extend 1/16"(2) beyond finished wall.
- J. After wall is erected, remove any plaster grout touching the fixture studs, bearing nuts washers and coupling.
- K. Place gasket in closet recess and set closet on studs protruding from wall making sure that closet outlet is centered on coupling.
- L. Place fiber washers on studs. Apply the two bottom and top left cap nuts, tighten securely. Apply the top right cap nut hand tight and snug up 1/4 turn with wrench.

NOTE: When installing closet with bar hanger support follow the same instructions as above, except that the hanger plate should be mounted on the top fixture studs. Adjust the top bearing nuts so that the face of the hanger extends 1/16"(2) beyond the finished wall, then lock in place with hex nuts.

NOTE: SEE REVERSE SIDE FOR ROUGH-IN TABLE.

NOTE: Dimensions shown in parentheses are in millimeters.

DRAWING NUMBER: S0550F

SIZE: A

SCALE: NONE

DATE: 1-17-86

APPROVED BY: BS

CHECKED BY: JD

DRAWN BY: CM

FIGURE NUMBER: 0550F

DIMENSIONS ARE SUBJECT TO MANUFACTURERS TOLERANCE AND CHANGE WITHOUT NOTICE

WE CAN ASSUME NO RESPONSIBILITY FOR USE OF SUPERSEDED OR VOID DATA

REV.	DATE	DESCRIPTION	BY	CKD. BY	WEIGHT POUNDS	VOLUME CUBIC FEET	FIGURE NUMBER
D	8-26-05	Revised Note	TBW	CL			0550F
C	05/21/01	Deleted 2" x 4"	JJ	CL			
B	8-7-96	Added Millimeters	EMB	BS			
A	7-20-93	Submittal Update	EMB	BS			

C



JAY R. SMITH MFG. CO.
 DIVISION OF SMITH INDUSTRIES, INC.
 POST OFFICE BOX 3237
 MONTGOMERY, ALABAMA 36109-0237 (USA)
 TEL: 334-277-8520 FAX: 334-272-7396 www.jrsmith.com



MEMBER OF:

LOCATION

ROUGH-IN TABLE

FOR RESIDENTIAL WATER CLOSETS

DIMENSION "H" ROUGH-IN HEIGHTS

FIXTURE MFG.	NAME	NUMBER	F	H
AM. STD.	GLENWALL	2093.100	7 1/2 (190)	4 1/8 (105)
CRANE	REXMONT	3-217	7 1/2 (190)	4 (100)
ELJER	WALFORD	091-7925, 7926, 7928, 7933	7 1/2 (190)	6 3/4 (170)

NOTE: Dimensions shown in parentheses are in millimeters.

DRAWING NUMBER
S0500BS

SIZE
A

SCALE:
NONE

DATE:
1-24-86

APPROVED BY:
SB

CHECKED BY:
JD

DRAWN BY:
CM

0500 SERIES

FIGURE NUMBER

WE CAN ASSUME NO RESPONSIBILITY FOR USE OF SUPERSEDED OR VOID DATA

DIMENSIONS ARE SUBJECT TO MANUFACTURERS TOLERANCE AND CHANGE WITHOUT NOTICE

C	8-26-05	Revised Table	TBW	CL	WEIGHT	VOLUME	FIGURE NUMBER
B	8-1-96	Added Millimeters	EMB	BS	POUNDS	CUBIC FEET	0500 SERIES
A	7-20-93	Submittal Update	EMB	BS			
REV.	DATE	DESCRIPTION	BY	CKD. BY			