

**ADJUSTABLE FIXTURE SUPPORTS
 FOR ELEVATED SIPHON JET WATER CLOSETS FOR WHEELCHAIR USERS
 DEEP ROUGH-IN TYPE**

VERTICAL FITTINGS WITH SIDE INLET

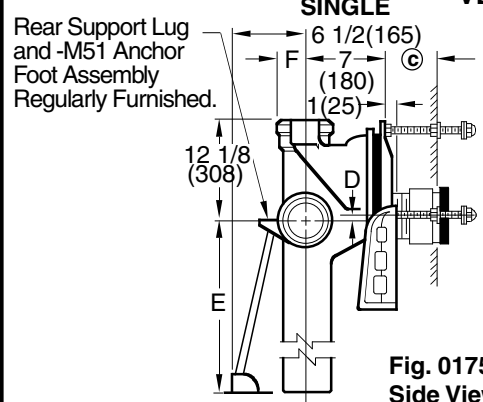

**Fig. 0175L
 Side View**

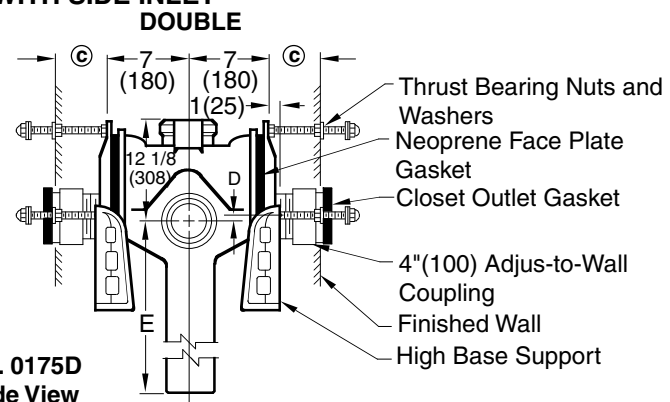

**Fig. 0175D
 Side View**

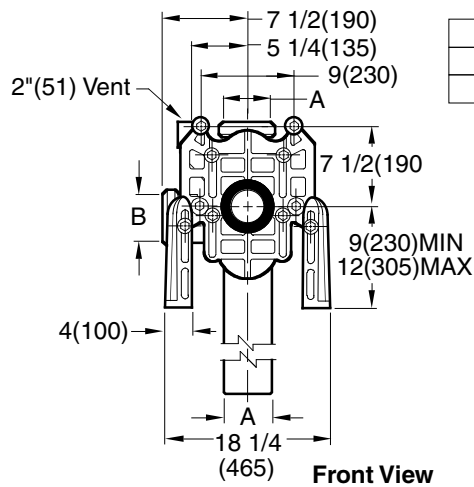

Front View

- Fig. 0175L ... CAULK-L.H. Long Barrel
- Fig. 0175R ... CAULK-R.H. Long Barrel
- Fig. 0175D ... CAULK-Double Long Barrel

NOTE: 1 1/2" (38) or 2" (51) tapped inlet available. Add suffix-N.
NOTE: Base Support must be firmly anchored to floor with four 1/2" (13) bolts provided by contractor.

The water closet outlet gasket regularly furnished is made of molded neoprene and designed to fit water closet outlet dimensions and configurations shown in ANSI Standard A112.19.2M-1995, Figure 13B. If gasket is not found to be compatible to fixture due to nonconformance of said fixture to ANSI A112.19.2M, then fixture manufacturer shall be consulted for a suitable gasket recommendation. Jay R. Smith assumes no liability for connections to fixtures which do not conform to these standards.

A & B size	D		E	F
	MIN	MAX		
4(100) x 4(100)	4 3/4(120)	8 3/4(220)	26 3/4(680)	3(76)

© DIMENSION - ADJUS-TO-WALL TYPE OUTLET CONNECTION

The Smith Adjus-to-Wall outlet connection provides adjustment at the face of the wall at the time the fixture is set; thus, compensating for wall construction variations. The © dimension is measured from the front of the face plate to the finished wall. To properly determine the length of nipple required, deduct 1" (25) from the © dimension. The Adjus-to-Wall coupling will provide 1/2" (13) horizontal adjustment in either direction with the coupling extended 5/16" (8) past face of the finished wall.

© dimension = 4" (100) (regularly furnished) consisting of nipple and Adjus-to-Wall coupling permitting adjustment from 3" (76) min. to 4" (100) max.

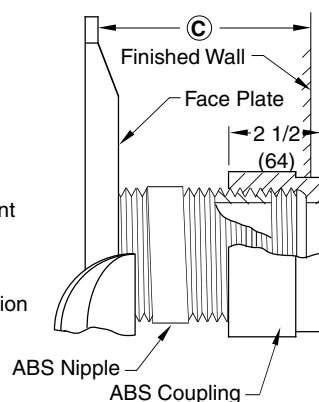

NIPPLE LENGTHS AVAILABLE

LENGTH	MIN	©	MAX
2 1/2 (64)	2 1/4 (57)	3 1/4 (83)	
*3 1/4 (83)	3 (76)	4 (100)	
*8 1/4 (210)	8 (205)	9 (230)	
10 (255)		10 3/4 (275)	
12 (305)	9 3/4 (250)	12 3/4 (325)	
15 (380)	11 3/4 (300)	15 3/4 (400)	
18 (455)	14 3/4 (375)	18 3/4 (475)	

17 3/4 (450)
NOTE: When nipple lengths between 3 1/4" (83) and 8 1/4" (210) are specified, the 8 1/4" (210) nipple will be supplied. Nipple must be cut to specified length by others.
 *ABS (Regularly Furnished) other lengths PVC.
NOTE: Dimensions shown in parentheses are in millimeters.

DRAWING NUMBER S0175
 SIZE A
 SCALE: NONE
 DATE: 1-3-85
 APPROVED BY: JD
 CHECKED BY: VGD
 DRAWN BY: CM
 FIGURE NUMBER 0175

WE CAN ASSUME NO RESPONSIBILITY FOR USE OF SUPERSEDED OR VOID DATA
 DIMENSIONS ARE SUBJECT TO MANUFACTURERS TOLERANCE AND CHANGE WITHOUT NOTICE

REV.	DATE	DESCRIPTION	BY	CKD. BY
G	7-1-98	Submittal Update	ASL	BS
F	1-23-98	Changed Callout	EMB	BS
E	3-3-97	Added Millimeters	EMB	BS
D	6-21-94	Revision	EMB	BS
C	7-8-93	Submittal Update	EMB	BS

WEIGHT POUNDS	VOLUME CUBIC FEET	FIGURE NUMBER 0175
---------------	-------------------	-------------------------------------

MODIFICATIONS & VARIATIONS FOR SIPHON JET WATER CLOSETS

RECOMMENDED SETTING OF CLOSET OUTLET CONNECTION AND FIXTURE STUDS

Manufacturers have slight differences in the depth of the closet horn and flange thickness of their closets. Usually the fixture support closet connection should extend 5/16" (8) beyond face of finished wall (Dimension "R") and the fixture studs 2 1/4" (57) (Dimension "X"). For exact dimensions please use the formulas below.

DETAIL A Formula for "R" is: $S + 1/16" (2) - D = R$.
 S = Depth of closet horn
 1/16" (2) = Distance closet is to set away from finished wall.
 D = 1/2" (13) for felt gasket and 3/8" (10) for neoprene gasket.
 R = Distance coupling should extend beyond finished wall.
 NOTE: When the fixture is installed, closet gasket must be compressed sufficiently to assure a gas and water-tight seal.

DETAIL B Formula for "X" is: $Y + 1/16" (2) + 9/16" (14) = X$.
 Y = Thickness of closet wall flange.
 1/16" (2) = Distance closet is to set away from finished wall.
 X = Distance supporting stud should extend beyond finished wall.
 NOTE: Bearing nuts and washers must be set to take full loading from the fixture allowing 1/16" (2) clearance between fixture and wall.

NOTE: Dimensions shown in parentheses are in millimeters.

OPTIONAL CLOSET OUTLET CONNECTIONS

TYPE NO. 2

NOTE: Coupling should extend beyond the wall adequately to apply sufficient and uniform pressure on the gasket to produce a watertight seal. It is the Installer's responsibility to make this final adjustment.

The type 2M outlet connection is used with floor mounted back outlet bowls. The 2M connection is an integral nipple/coupling whose length is specified by the © dimension. The 2M can accommodate a smaller © dimension than the type 2 nipple/coupling.

	MIN	©	MAX
TYPE 2M	1 1/4" (32)	5 1/2" (140)	

*Type No. 2 should be used when Max. dimension is exceeded.

SUFFIX -M12 EXPOSED FLUSH VALVE SUPPLY SUPPORT

Provides support and alignment for the supply pipe to an exposed flush valve; must be specified for either 1" (25) copper tube or 1" (25) iron pipe.

TYPE -M73 Closet outlet connector for use with stainless steel fixture

TYPE -M74 Closet outlet for use with stainless steel fixture

SUFFIX -M13 TILING FRAME - POLYSTYRENE

-M40 WATER CLOSET SUPPORT FOR WIDE PIPE CHASE

-M40 Recommended when © dimension exceeds 7" (180).

FIGURE NUMBER	D	2-27-12	Rev. Note Type 2 outlet Added Note Added Millimeters	TBW	AM	WEIGHT POUNDS	VOLUME CUBIC FEET	FIGURE NUMBER
	C	12-10-03		RN				
	B	2-26-96		EMB	BS			
REV.	DATE	DESCRIPTION	BY	CKD. BY				

DRAWING NUMBER S0100BS
 SCALE: NONE
 DATE: 1-16-85
 APPROVED BY: JD
 CHECKED BY: CR
 DRAWN BY: VGD
 DIMENSIONS ARE SUBJECT TO MANUFACTURERS TOLERANCE AND CHANGE WITHOUT NOTICE
 WE CAN ASSUME NO RESPONSIBILITY FOR USE OF SUPERSEDED OR VOID DATA