

K



JAY R. SMITH MFG. CO.
 DIVISION OF SMITH INDUSTRIES, INC.
 POST OFFICE BOX 3237
 MONTGOMERY, ALABAMA 36109-0237 (USA)
 TEL: 334-277-8520 FAX: 334-272-7396 www.jrsmith.com



LOCATION

DRAWING NUMBER
S4140

SIZE
A

SCALE:
NONE

DATE:
2-16-70

APPROVED BY:
JM

CHECKED BY:
BH

DRAWN BY:
RK

FIGURE NUMBER
4140 SERIES

DIMENSIONS ARE SUBJECT TO MANUFACTURERS TOLERANCE AND CHANGE WITHOUT NOTICE

WE CAN ASSUME NO RESPONSIBILITY FOR USE OF SUPERSEDED OR VOID DATA

TILE FLOOR CLEANOUTS WITH "TWIS-TO-FLOOR®" ADJUSTABLE TOPS

ROUND NICKEL BRONZE TOP WITH TILE RECESS

FUNCTION: For use in floors and areas which are covered with a floor covering such as asphalt or vinyl tile, linoleum, etc., bearing foot and medium load wheeled traffic. Tile recess receives inlay of floor material, presenting an unobtrusive appearance. Allows for easy floor level adjustment.

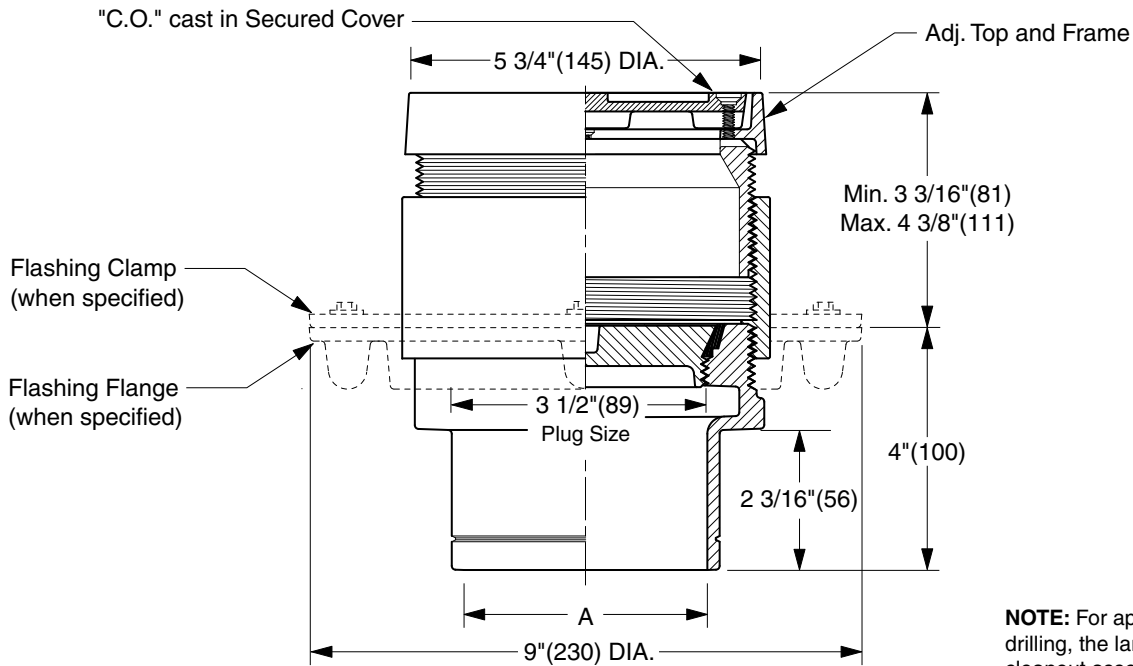

NOTE: For applications using core drilling, the largest diameter of the cleanout assembly is 6 5/16\"(160).

TWIS-TO-FLOOR® ADJUSTMENT

NO-HUB OUTLET

"A" (Pipe Size) = 02(50), 03(75), 04(100) or 05(125)

- Fig. 4140S.....Gasket Seal - ABS Plug
- Fig. 4141S.....Gasket Seal - Bronze Plug
- Fig. 4143S.....Taper Thread - Bronze Plug
- Fig. 4144S.....Taper Thread - ABS Plug

(Twis-to-Floor® design shown with gasketed plug.)

NOTE: Dimensions shown in parentheses are in millimeters.

REGULARLY FURNISHED:

Duco Cast Iron Cleanout with Round Adjustable Secured Nickel Bronze Top with 1/8\"(3) Tile Recess. Closure Plug Type as Indicated By Figure Number Selected.

VARIATIONS:

- Flashing Flange -F
- Flange with Flashing Clamp -F-C
- Vandal Proof Top -U

OPTIONAL MATERIALS:

- Galvanized Cast Iron -G
- Polished Bronze Top -PB

K	12/17/04	Added Core-Drilling Note	JJ	CL	WEIGHT POUNDS	VOLUME CUBIC FEET	FIGURE NUMBER 4140 SERIES
J	07/29/02	Corrected Clamp & Flange view	JJ	CL			
H	05/07/01	Edited Outlet Text	JJ	CL			
G	10/23/00	New design	JJ	BS			
REV.	DATE	DESCRIPTION	BY	CKD. BY			



JAY R. SMITH MFG. CO.
 DIVISION OF SMITH INDUSTRIES, INC.
 POST OFFICE BOX 3237
 MONTGOMERY, ALABAMA 36109-0237 (USA)
 TEL: 334-277-8520 FAX: 334-272-7396 www.jrsmith.com



MEMBER OF:

LOCATION

TILE FLOOR CLEANOUTS WITH "TWIS-TO-FLOOR®" ADJUSTABLE TOPS

ROUND NICKEL BRONZE TOP WITH TILE RECESS

FUNCTION: For use in floors and areas which are covered with a floor covering such as asphalt or vinyl tile, linoleum, etc., bearing foot and medium load wheeled traffic. Tile recess receives inlay of floor material, presenting an unobtrusive appearance. Allows for easy floor level adjustment.

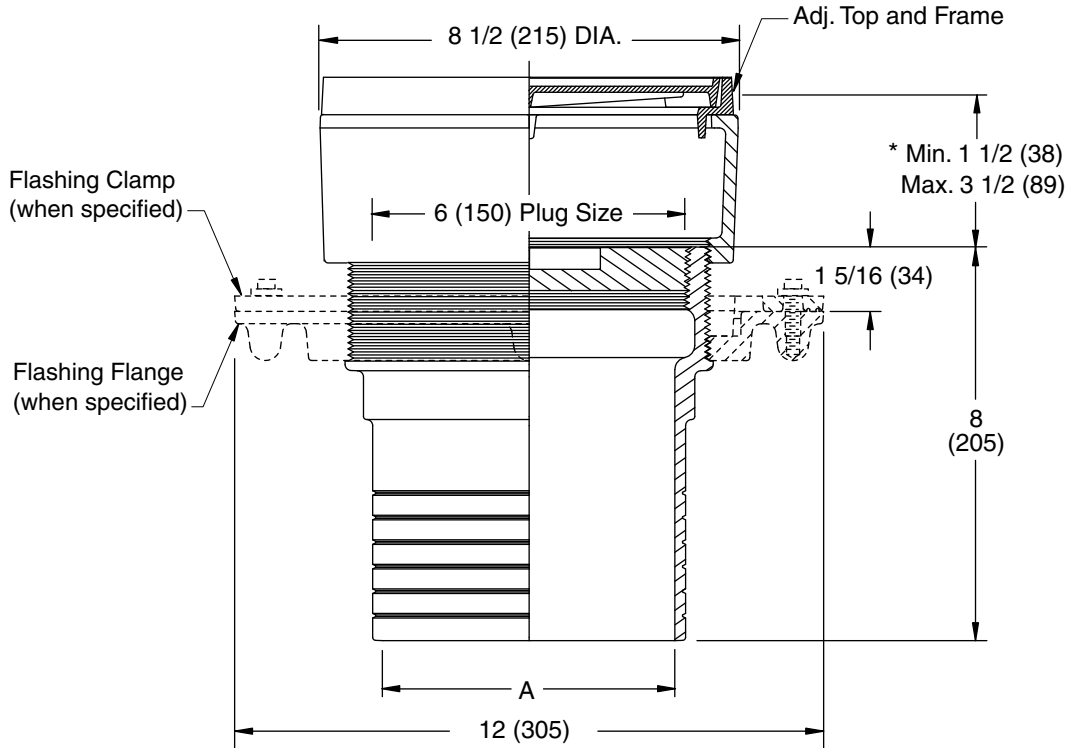

SPIGOT OUTLET▲

"A" (Pipe Size) = 06(150) & 08(200)

▲ Sized for Service Weight and/or NO-HUB.

* When Flange-F is specified Min. 1 1/2 (38) becomes 2 (51)

"TWIS-TO-FLOOR®" ADJUSTMENT

SPIGOT OUTLET▲

Fig. 4143S.....Taper Thread - Bronze Plug

REGULARLY FURNISHED:

Duco Cast Iron Cleanout with Taper Thread Bronze Plug and Round Adjustable Secured Nickel Bronze Top with 1/8 (3) Tile Recess.

VARIATIONS:

- Flashing Flange -F
- Flange with Flashing Clamp -F-C
- Vandal Proof Top -U

OPTIONAL MATERIALS:

- Galvanized Cast Iron -G
- Polished Bronze Top -PB

NOTE: Dimensions shown in parentheses are in millimeters.

DRAWING NUMBER
S4140BS

SIZE
A

SCALE:
NONE

DATE:
5-5-06

APPROVED BY:
CEL

CHECKED BY:
CL

DRAWN BY:
RN

FIGURE NUMBER
4143

WE CAN ASSUME NO RESPONSIBILITY FOR USE OF SUPERSEDED OR VOID DATA

REV.	DATE	DESCRIPTION	BY	CKD. BY

WEIGHT POUNDS	VOLUME CUBIC FEET

FIGURE NUMBER 4143
