

THE BOSS TEE

The Jay R. Smith Mfg. Co.® Cleanout and Test Tee, Fig. No. 4505

The Boss Tee's Role in the Piping System

The Boss Tee is designed to work double duty in the sanitary DWV piping system: during construction to hydrostatically test the piping system for leaks then after testing as a standard cleanout tee.

When The Boss Tee is closed off with an internal plug, it can be used to test DWV piping from one to three floors, or 10 to 30 feet of head pressure (approximately 5 to 15 P.S.I.) above the cleanout tee thus eliminating the need for an inflatable plug in the vertical stack.

The Cleanout and Test Tee Does the Work for You

Figure number 4505, cleanout and test tee is engineered to be installed in a concealed drainage line where a cleanout tee is desired.

Figure No. 4505 Cleanout and Test Tee



To test the piping system with The Boss Tee, a raised head plug needs to be installed into the internal threading of the cleanout tee to seal off the stack. At the front of the cleanout tee remove the 1/2" raised head plug from the test port and add a water pressure gauge and boiler drain valve. Now the system is ready to be filled to its highest point. The pressure gauge installed before the boiler drain valve will indicate any leaks during testing. It is an excellent verification point for the inspector.

When testing and inspection are complete, connect a hose to the boiler drain valve and drain the piping system either down the stack, to the nearest floor drain, or acceptable drainage point.

Once the system is drained, remove the internal plug, pressure gauge and boiler drain valve from the cleanout tee for use on the next Boss Tee test. Upon removal, plug the test port and install the taper threaded bronze plug into the front of the cleanout tee.

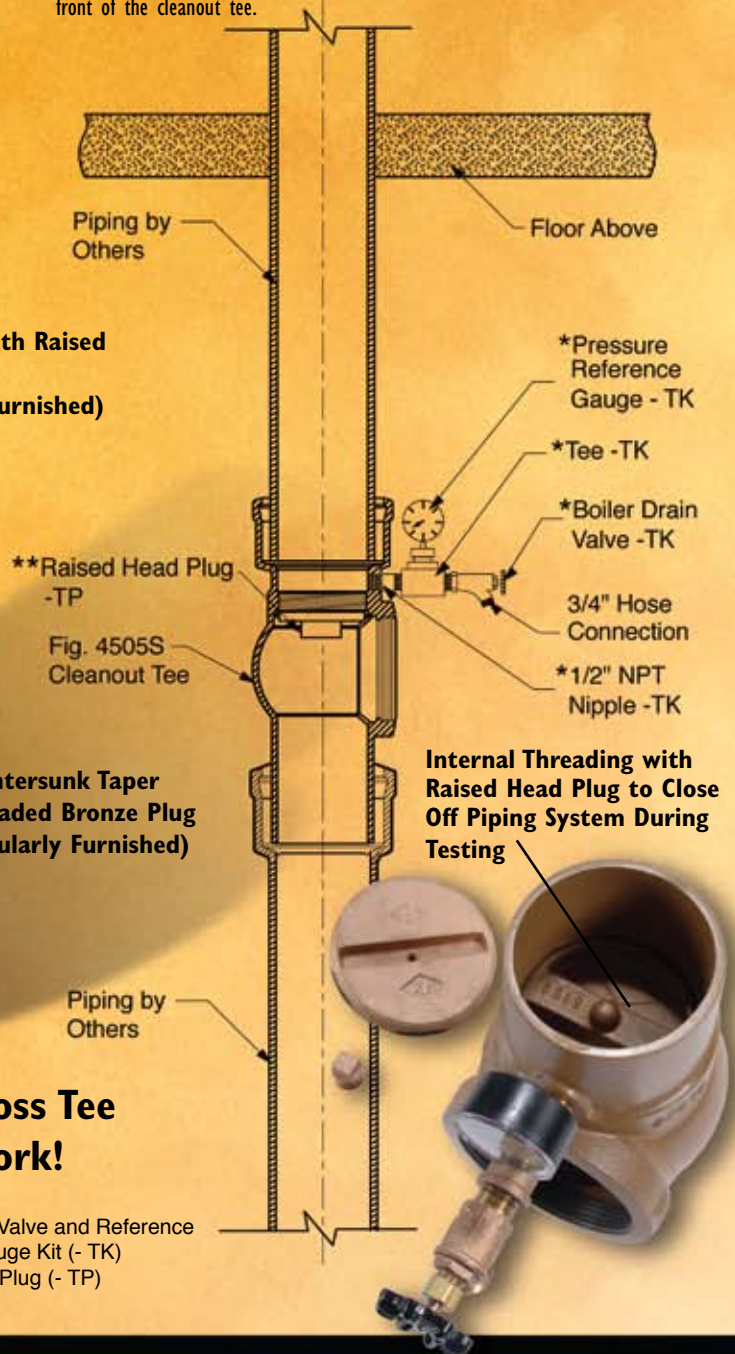

Let The Boss Tee
Do The Work!

SMITH®
JAY R.
SMITH MFG. CO.®
CUSTOMER
DRIVEN

*Test Valve and Reference
Gauge Kit (- TK)
**Test Plug (- TP)

Testing Procedures and Advantages

Suggested Test Procedures:

1. Remove existing cleanout plug at face of tee.
2. Install a raised head plug into the internal threading.
3. Remove plug from the test port connection.
4. Thread 1/2" NPT nipple with tee, pressure reference gauge and boiler drain valve into the test port.
5. Connect one end of a water hose to the boiler drain valve and the other end to a water supply and fill piping for testing. The boiler drain valve must be in the open position.
6. When piping is full of water, shut off the water supply and close the boiler drain valve.
7. When test is complete, disconnect the water hose from the water supply and place in a floor drain or other acceptable drainage point and open boiler drain valve to drain piping.
8. When piping is completely drained reverse steps 1 through 7.

NOTE: The Boss Tee can be used to test the piping system in the customary manner by installing a plug into the internal threading and filling the piping from the top.

Shown being set-up to hydrostatically test the DWV piping



Raised Head Plug

The Boss Tee Advantages

- **Safety** – contractor not required to work inside of stack with 5-15 PSI pressure just upstream of the plug.
- **Reduces the chance of mold** – due to water spilling inside the chase.
- **No inflatable plug in the vertical stack** – to insert or remove during testing.
- **Reliability** – better testing results because of reliable closure of the stack.
- **Time savings** – test up to three floors; the inspector can use the gauge to verify pressure in the line.
- **Large, spherical opening in the fitting** – allows for easy hand access for line testing, inspection, and cleaning.
- **Controlled testing environment** – provides contractor with effective means of filling and draining the piping system.
- **Cleanout tee remains in the stack after testing** – to be used for future maintenance and testing.

Let The Boss Tee Do The Work! Figure No. 4505

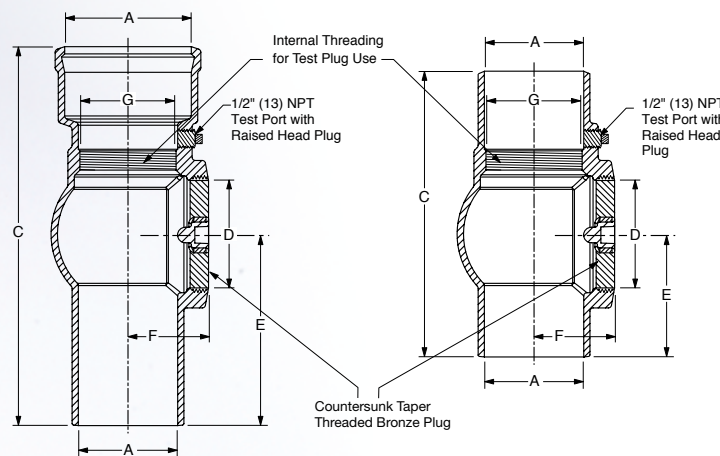

FIG. 4505S.....HUB and SPIGOT

A PIPE SIZE	C	D PLUG SIZE	E	F	G SIZE
03(75)	13 1/2(345)	3(76)	7 (180)	2 1/2(64)	2 1/2(64)
04(100)	14 3/4(375)	4(100)	7 1/2(190)	3 (76)	3 1/2(89)
06(150)	17(430)	6(150)	8 1/2(215)	4(100)	5(125)

Spigot Outlet Sized for Service Weight and/or NO-HUB.

FIG. 4505Y.....NO-HUB

A PIPE SIZE	C	D PLUG SIZE	E	F	G SIZE
03(75)	9 1/4(235)	3(76)	3 3/4(95)	2 1/2(64)	2 1/2(64)
04(100)	10 1/2(265)	4(100)	4 1/2(115)	3(76)	3 1/2(89)
06(150)	14(365)	6(150)	6 1/4(160)	4(100)	5(125)

NOTE: Dimensions shown in parentheses are in millimeters.

VARIATIONS:

- Test Valve and Reference Gauge Kit - TK
- Test Plug - TP

REGULARLY FURNISHED:

Duco Cast Iron Cleanout Tee with additional Internal Threading, 1/2" (13) NPT Test Port with Raised Head Plug and Countersunk Taper Threaded Bronze Plug.

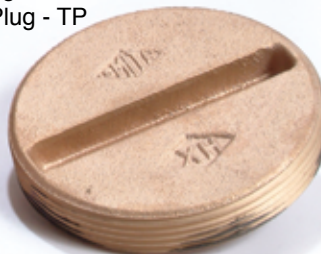

Countersunk Taper Threaded Bronze Plug

Contact your local representative

SMITH® JAY R. SMITH MFG. CO.®
DIVISION OF SMITH INDUSTRIES, INC.
POST OFFICE BOX 3237
MONTGOMERY, ALABAMA 36109-0237 (USA)
TEL: 334-277-8520 FAX: 334-272-7396 www.jrsmith.com

