



# CAROUSEL® ROOF DRAIN - A ROOF DRAIN WITH ADJUSTABLE EXTENSION

**FUNCTION:** Universal cast iron membrane clamping collar and dome are designed for retrofit roof applications where the existing main roof drain body is to remain in place and continue to be operative. The bolting lugs of this collar match the bolt pattern of the majority of the common roof drain bodies and generally conform to the surface angles of the flange. This allows easy replacement along with adequate pressure on the membrane to insure water tightness. The collar is designed to accompany most 15" (380) and 16" (405) diameter roof drain bodies with bolt circles ranging 7 1/4" (185) to 10 3/4" (275) in diameter. It is recommended to extend roof membrane into the sump of existing roof drain body.

**Fig. # 1015**  
Carousel® Roof Drain

**Product Features:**

- Used in flat roofs of any construction.
- Large, low profile dome for quick drainage and protection against debris.
- Adjustable extension for different insulation thicknesses.
- Wide clamping surface to hold flashing and roofing materials.
- Reversible collar allows for two extension ranges:
  - Low Position – MIN 1 1/4"; MAX 2 1/2"
  - High Position – MIN 2 1/4"; MAX 4 1/4"
- Combined flashing clamp and gravel stop.

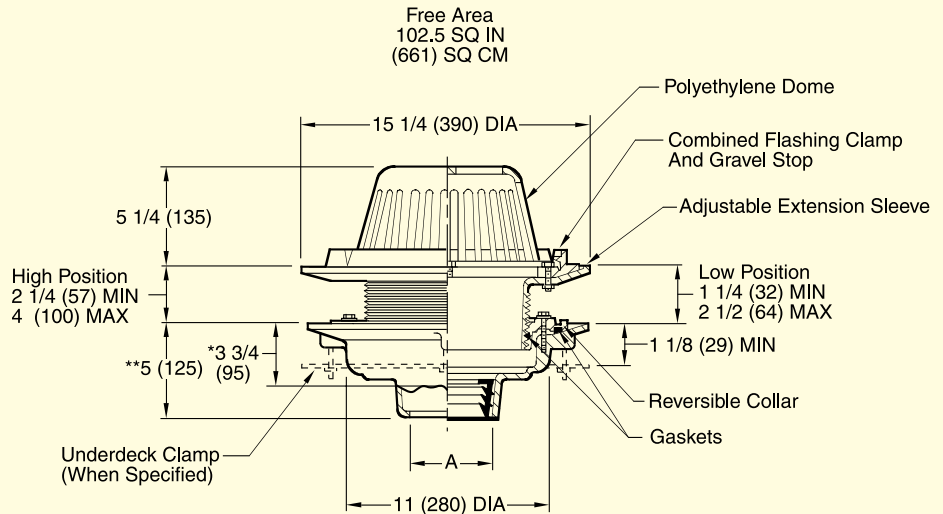

\*This dimension to internal stop of Speedi-Set Gasket  
 \*\*Same for Caulk, NO-HUB and Speedi-Set, 3 3/4 (95) for Threaded

A (Pipe Size) = 02(50), 03(75), 04(100), 05(125) or 06(150)

□ Fig. 1015C ..... CAULK OUTLET  
 □ Fig. 1015Y ..... NO-HUB OUTLET

recommended deck opening	
with suffix -R	17 (430) DIA
less Suffix -R	14 (355) DIA

**Note:** See reverse side for assembly instructions.

**REGULARLY FURNISHED:**

Duco Cast Iron Body with Adjustable Extension Sleeve, Reversible Collar, Combined Flashing Clamp and Gravel Stop, with Polyethylene Dome.

**OPTIONAL MATERIALS:**

- Aluminum Dome -AD
- Cast Iron Dome -CID
- Galvanized Cast Iron -G
- Rough Bronze Dome -RBD

**VARIATIONS:**

- Expansion Joint (Specify Fig. 1710)
- "L" Shaped Underdeck Clamp -CL
- L Speedi-Set Service Weight 02(50), 03(75) & 04(100)" sizes only
- LXH Speedi-Set Extra Heavy 02(50), 03(75) & 04(100)" sizes only
- Secondary Flashing Clamp -C2
- Sump Receiver -R
- Underdeck Clamp -C
- Vandal Proof Dome -U
- Side Outlet Drain (Specify Fig. 1025)
- T Threaded Outlet

**NOTE:** Dimensions shown in parentheses are in millimeters.