

B

SMITH® JAY R. SMITH MFG. CO.®
 DIVISION OF SMITH INDUSTRIES, INC.
 POST OFFICE BOX 3237
 MONTGOMERY, ALABAMA 36109-0237 (USA)
 TEL: 334-277-8520 FAX: 334-272-7396 www.jrsmith.com

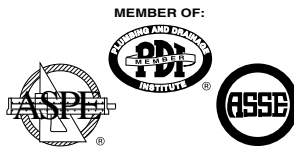

LOCATION

DRAWING NUMBER
S9848

SIZE
A

SCALE:
NONE

DATE:
03/22/00

APPROVED BY:

CHECKED BY:

DRAWN BY:
JJ

9848

FIGURE NUMBER

WE CAN ASSUME NO RESPONSIBILITY FOR USE OF SUPERSEDED OR VOID DATA

DIMENSIONS ARE SUBJECT TO MANUFACTURERS TOLERANCE AND CHANGE WITHOUT NOTICE

SUMP BOX

FUNCTION: Used as a collector for downspouts, or other surface water. Well suited for high flow rates, solid and sludge handling, chemical containment and pump housing.

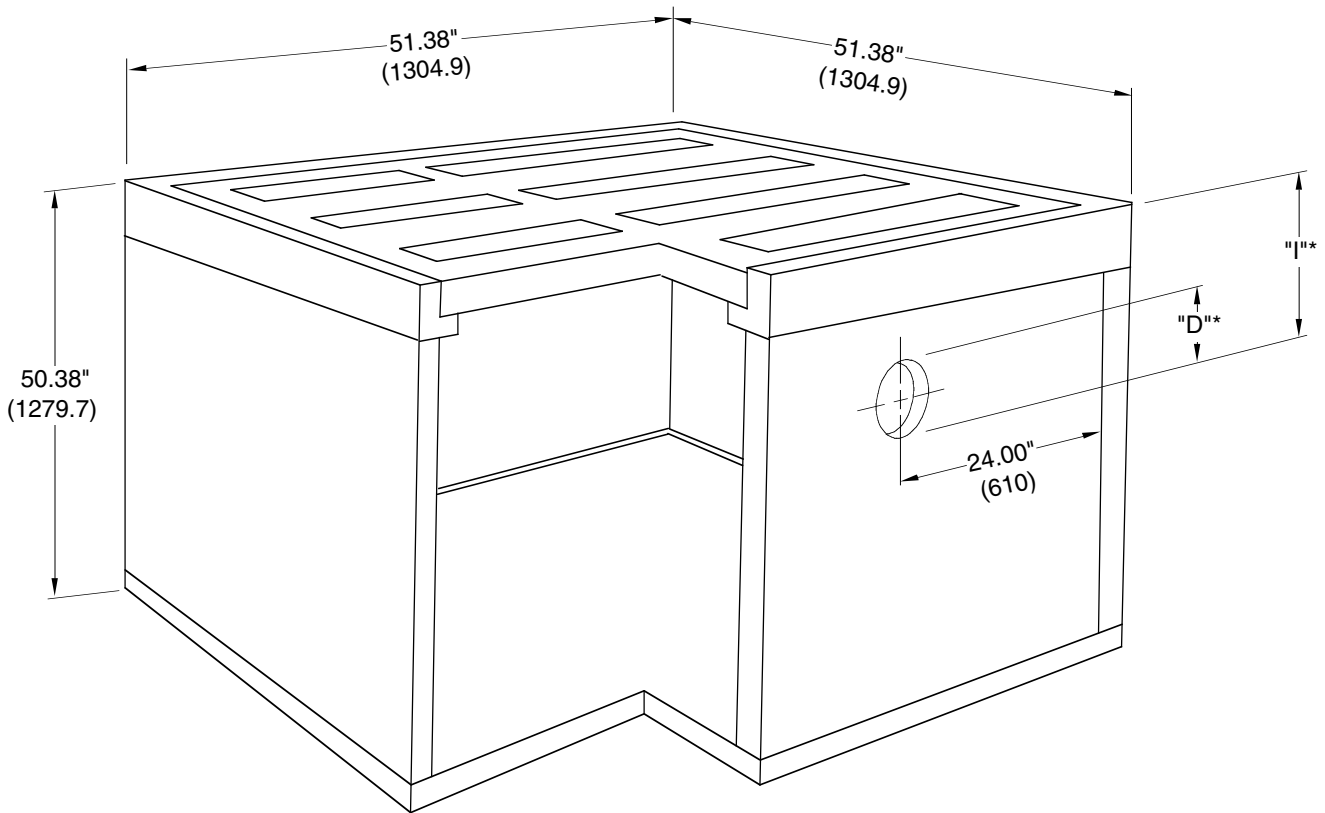

*Specify Outlet Diameter and Invert location.

"D"	
"I"	

REGULARLY FURNISHED:
 Polymer Concrete Catch Basin with 475 Gallon(1798 liters) Holding Capacity and Duco Coated Cast Iron Grate and Frame. Load Class "C". Specify Diameter and Location of Invert. Weight of Box Only = 808 lbs.(368kg).

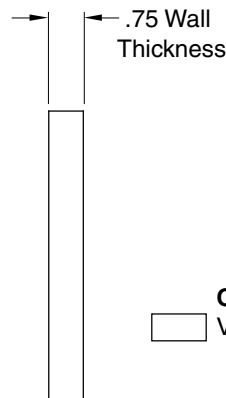

Typical Wall Section

OPTIONAL MATERIAL:
 Vinylester.



REV.	DATE	DESCRIPTION	BY	CKD. BY	WEIGHT POUNDS	VOLUME CUBIC FEET	FIGURE NUMBER
B A	7-14-03 9-16-02	Revised Dims, Capacity and Weight Added New ACO Logo	JJ RN	MD MD			9848